

Parts and Accessories. Installation Instructions.



Alarm Retrofit Kit

MINI Cooper and Cooper S (R56), select Vehicle Production 12/06 - On

Vehicle must have optional alarm pre-wiring, which is 100% option for US spec vehicles.

Retrofit kit No. 65 73 0 417 646 Alarm Retrofit Kit

Installation time

The installation time is 1.75 hours, but this may vary depending on the condition of the car and the equipment in it.

Suggested installation time includes re-coding of the vehicle only for this retrofit kit. This time is based on a vehicle that is at the current software level and does not require any updates. Before installing this accessory into the vehicle, the vehicle should be connected to the DIS and checked for software updates. If updates are available the vehicle should be programmed prior to installing this accessory.

If vehicle is under warranty, the costs of programming prior to retrofit should use defect code 72 60 93 02 00.

Please refer to SI B09 05 01 for latest MINI approved CIP Retrofit procedures.

Please refer to SI M01 01 07 – Defect Code for Programming Prior to Accessory Retrofit.

Important information

The instructions below are developed for MINI vehicles and are not to be compared to any other existing instructions for vehicles other than MINI. No methods other than those specified in this document are to be used for installation in MINI vehicles. Left and right are determined from the driver's seat.

Carefully read all instructions and supplements before proceeding with the installation. Reference should be made to TIS for instructions dealing with a stock part of the vehicle but not stated in detail in these instructions.

The instructions were complete and up to date at time of publication; however, changes to the vehicle or installation may have occurred. Please report any problems or changes noted with the installation to MINI Technical Hotline, along with VIN, date of manufacture and as much detail as possible.

Do not archive the hard copy of these installation instructions since daily updates are made by ASAP.

Parts information

Contents of kit – P/N 65 73 0 417 646

Description	Qty	MINI Part Number
Alarm siren-tilt sensor	1	65 75 6 970 943
Bracket (siren-tilt sensor)	1	65 75 2 753 429
Hood switch	1	61 31 9 119 052
Bracket (hood switch)	1	61 31 6 932 791
Interior Ultrasonic sensor	1	65 75 3 449 417
Countersunk screw	1	07 13 0 658 509
M6 hex nut with captive washer	3	07 12 9 904 000

Contents

Section	Page
1. Siren/Tilt Sensor Installation	4
2. Hood Switch Installation	6
3. Interior Ultrasonic Module Installation	7
4. Retrofit Coding	8
5. Wiring Diagramm	10

1. Siren/Tilt Sensor Installation

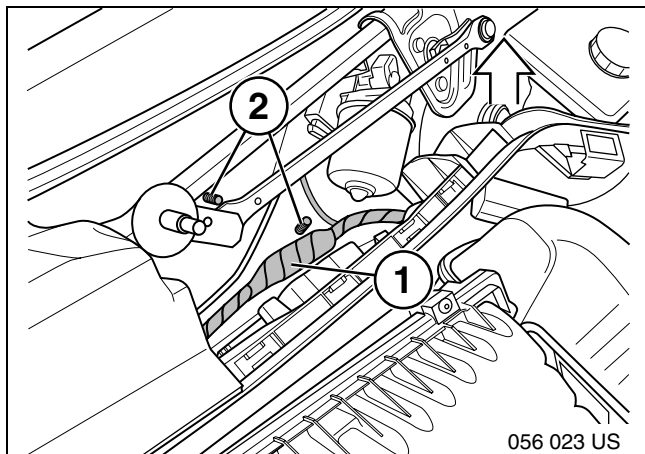

1.1
Disconnect negative battery terminal.
Refer to TIS 12 00 ...

1.2
Use puller (special tool 61 6 130) to remove LH wiper arm from wiper arm linkage.
Refer to WebTIS 61 61 081.

1.3
Remove left cowl panel cover.
Refer to WebTIS 51 13 123.

1.4
Locate 6-position black connector (1) **X14147** found taped to wire harness.

1.5
Carefully remove protective tape to expose connector.

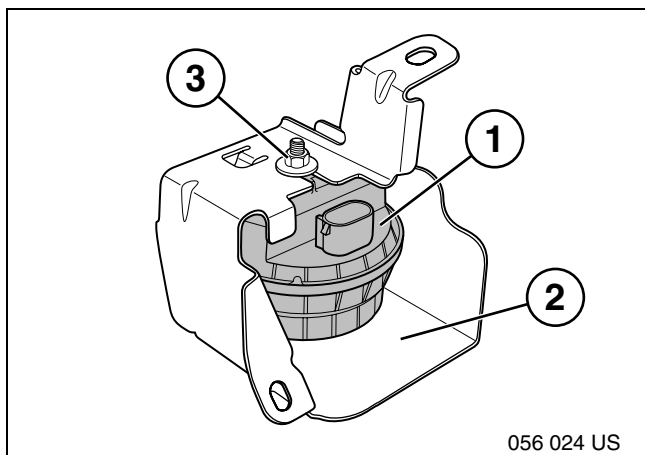

1.6
Attach alarm siren-tilt sensor (1) to mounting bracket (2) and secure in place using M6 nut with captive washer (3).

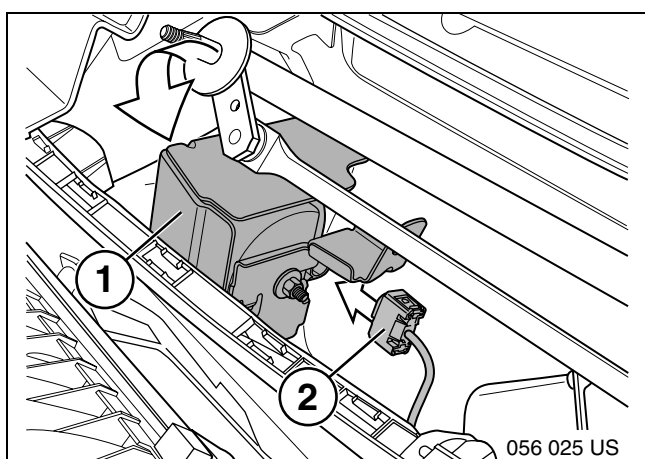

1.7
Direct alarm siren-tilt sensor/mounting bracket assembly (1) into position underneath windshield wiper arm linkage in LH cowl area as shown.

1.8
Connect black 6-position connector (2) **X14147** to siren/tilt sensor as shown.

1. Siren/Tilt Sensor Installation

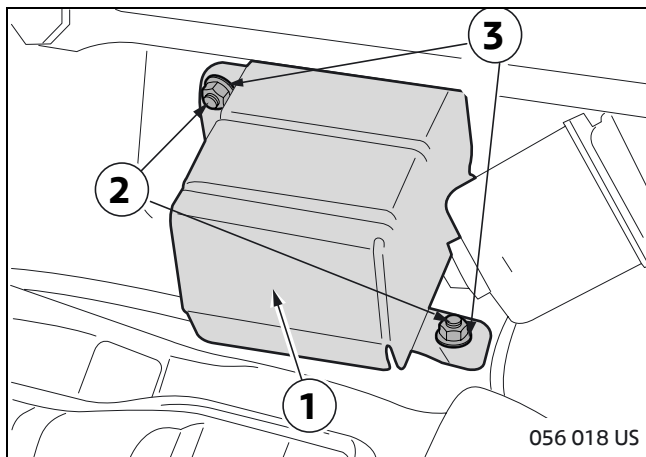

1.9
Refer to illustration 056 023 US for location of mounting studs (2) to mount alarm siren-tilt sensor/mounting bracket assembly.

1.10
Position alarm siren-tilt sensor/mounting bracket assembly (1) onto mounting location studs (2) and secure in place with M6 hex nut with captive washer (3).

2. Hood Switch Installation

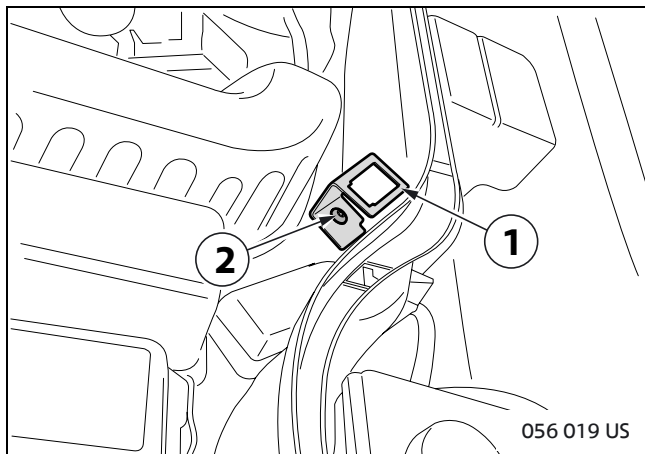

2.1
Position hood switch bracket (1) to mounting location as shown and secure in place with countersunk screw (2).

Note: Make sure "corner notch" on bracket faces rearward and fits into base mounting tab.

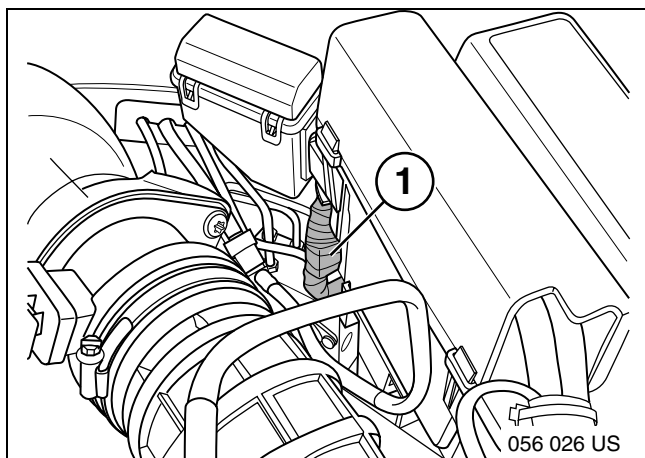

2.2
Locate 3-position black connector X161 found taped to wire harness (1).

2.3
Carefully remove protective tape to expose connector.

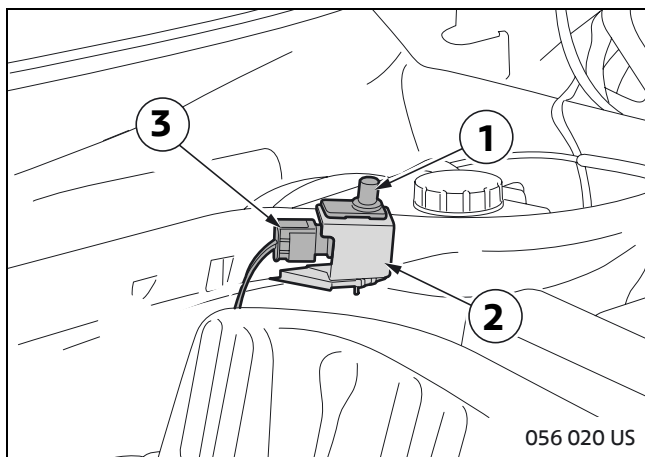

2.4
Insert hood switch (1) into hood switch bracket (2) with connector facing cowl area as shown.

2.5
Connect hood switch harness connector (3) to hood switch (2) as shown.

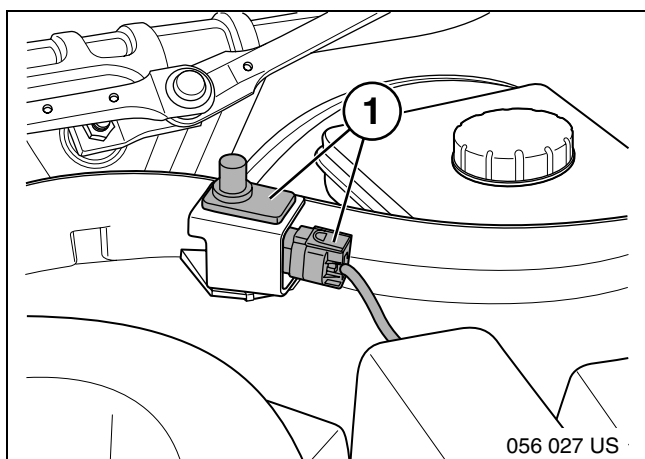

Note: On some early production vehicles the hood switch harness may be of insufficient length to make connection as shown in illustration 056 020 US.

To remedy this condition, remove hood switch from bracket and reinsert hood switch with connector facing front LH fender area. This should allow connection of harness to hood switch (1) as shown in illustration 056 027 US.

3. Interior Ultrasonic Module Installation

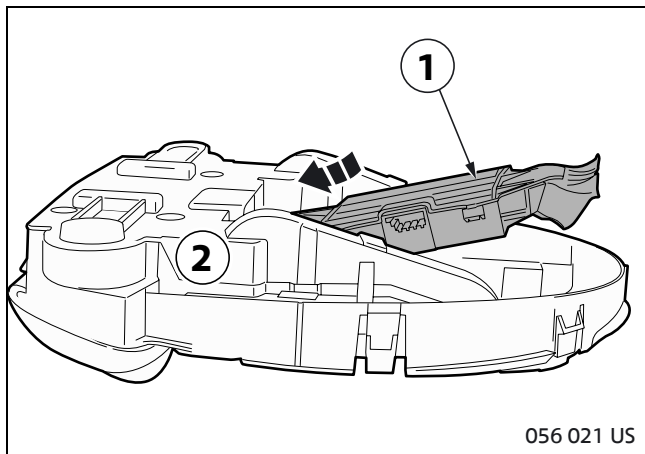

3.1 Remove roof operating unit.
Refer to WebTIS 63 31 029.

3.2 Install ultrasonic module (1) into roof operating unit (2) as shown.

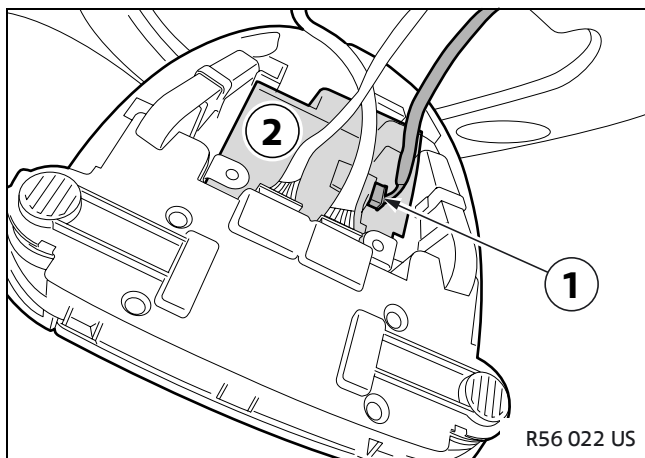

3.3 Connect 4-position black connector (1) to ultrasonic module (2) as shown.

3.4 Reinstall all previously removed or displaced components and trim parts.

3.5 Reconnect negative battery terminal.

4. Retrofit Coding

Note: Please refer to SI B09 05 01 for latest Progman retrofit procedure before starting vehicle coding.

Reconnect negative battery terminal.

Retrofit DWA (alarm system) using Progman 25.xx or later.

Follow approved Progman Retrofit procedures until Retrofit selection appears then:

Program session

Program selection:

- **Select** "Load SW"

Have control modules been replaced on this car?

- **Select** "No"

Screen will appear stating "Fitted control modules are being determined, followed by Select control module to be processed"

- **Select** "Retrofits"

Screen will appear stating "Selecting Retrofits"

- **Select** "Retrofits"

Screen will appear stating "Retrofits have been added"

- **Select** "DWA"

Screen will appear stating "Select sub function for retrofits or cancel with arrow in navigational column"

- **Select** "Added"

Screen will appear stating "Retrofitting Antitheft alarm system selected"

- **Select** "Continue"

Screen will appear stating "The voltage is being tested; vehicle context is being checked again" followed by "Measures plan is being determined"

Screen will appear stating "A measures plan has been created and accepted. It takes 1 minute to execute this measures plan"

- **Select** "Start"

Screen will appear stating "The CKM values are being saved"; "The GM control module _____";
"The CKM values are being restored"

Final Report

- **Select** "Finish"

4. Retrofit Coding

To determine if DWA code number 302 is in vehicle order (VO):

- **Select** "Change"
- **Select** "Vehicle"
- **Select** "Complete encoding"

Screen will appear stating "You start coding the entire vehicle with the following functions"

- **Select** "Continue"

Screen will appear stating "Should coding of the entire car be started now?"

- **Select** "Yes"

Screen will appear stating "Measures Plan is being determined"

Screen option will appear showing Measures Plan, DWA option code number 302 should be the last number listed in the vehicle order.

- **Select** "Print" if a printed copy of measures plan is desired.
- **Select** "End" **NOTE: DO NOT SELECT ACCEPT**

Upon completion of anti-theft alarm system coding, conduct alarm system test to verify functionality of alarm system.

5. Wiring Diagramm

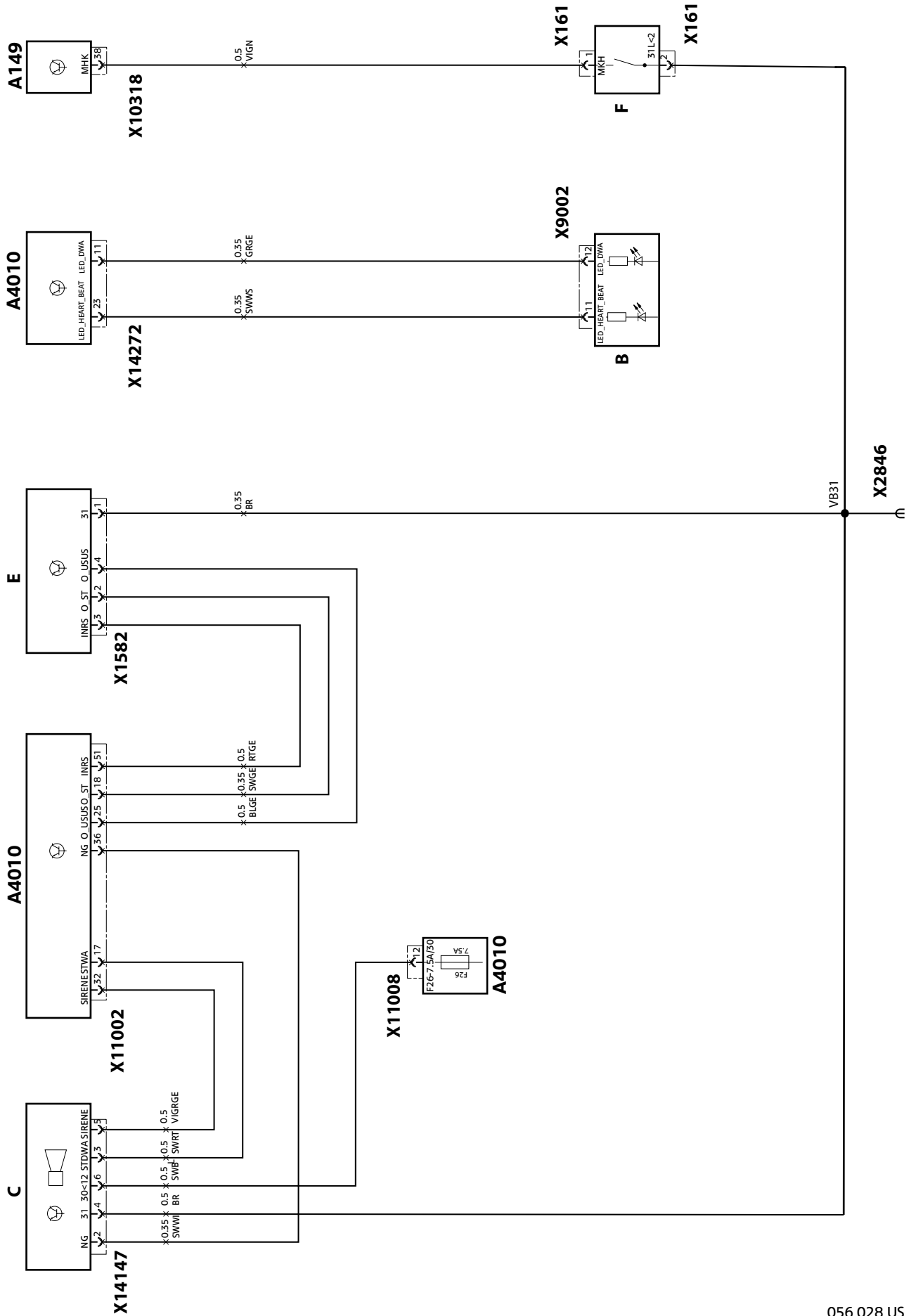

056 028 US

5. Wiring Diagramm

Legend

A149	Car Access System (CAS) - control unit
A4010	Junction box
B	Odometer
C	Siren-tilt sensor
E	Interior Ultrasonic module
F	Hood contact switch
X161	Connector housing 3-position
X1582	Connector housing 4-position
X2846	Ground post
X9002	Connector housing 18-position
X10318	Connector housing 41-position
X11002	Connector housing 52-position
X11008	Connector housing 18-position
X14147	Connector housing 6-position
X14272	Connector housing 24-position

Cable Colors

BL	Blue
BR	Brown
GE	Yellow
GN	Green
GR	Grey
RT	Red
SW	Black
VI	Violet
WS	White