

# Original MINI Accessories. Installation Instructions.



## iPod Interface Retrofit MINI ONE and COOPER (R 56) MINI COOPER S (R 56)

These installation instructions are only valid for cars with SA 672 (CD changer) or SA 694 (CD changer preparation).

**Retrofit kit No.** 65 41 0 422 163 iPod interface retrofit kit

### Installation time

The installation time is approx. **1.25 hours**. This may vary depending on the condition of the car and the equipment in it.

In general the car must be upgraded to the latest I stage status by flashing before starting the work. Depending on the production age of the car and the work already carried out on the car, the programming times will vary, which means that we cannot quote a specific time at this point.

The installation time does not include any time for programming/encoding, as this depends on the age of the car and the equipment in it.

### Important information

These installation instructions are primarily designed for use within the MINI dealership organisation and by authorised BMW service companies.

In any event the target group for these installation instructions is specialist personnel trained on MINI cars with the appropriate specialist knowledge.

All work must be completed using the latest BMW repair manuals, circuit diagrams, servicing manuals and work instructions in a rational order using the prescribed tools (special tools) and observing current health and safety regulations.

**In the event of any installation or function problems, restrict the troubleshooting session to about 0.5 hours for mechanical work or 1 hour for electrical work.**

In order to reduce costs and avoid any additional expense, send a query immediately to the Technical Parts Support via the Aftersales Assistance Portal (ASAP).

Specify the following information:

- Chassis number
- Part number of the retrofit kit
- A precise description of the problem
- Any work already carried out.

Do not archive the hard copy of these installation instructions since daily updates are made by ASAP!

### Pictograms



Denotes instructions that draw your attention to special features.

◀ Denotes the end of the instruction or caution text.

## **Installation information**

All pictures show LHD cars; proceed accordingly on RHD cars.

Ensure that the cables/lines are not kinked or damaged as you install them in the car. Costs incurred as a result of this will not be reimbursed by BMW AG.

Additional cables/lines that you install must be secured with cable ties.

If the specified PIN chambers are occupied, bridges, double crimps or twin-lead terminals must be used.

After the installation work the retrofit must be programmed / coded using SSS (software service station) via the **Retrofit** path.

When routing fibre optic cables, make sure the bending radius is no less than 25 mm.

## **Installation instructions for cars with SA 672 (CD changer)**

- The CD changer must be removed.

## **Ordering instructions for cars with SA 493 (storage package) or SA 672 (CD changer)**

The iPod-Interface storage tray **H** is not included in the retrofit kit and must be ordered separately (part no. 65 15 0 428 922).

## **Special tools required**

00 9 317, Trim wedge

## Contents

Section	Page
1. Parts list .....	4
2. Preparatory work .....	5
3. Connection diagram .....	6
4. Installation and cabling diagram .....	7
5. Installation in cars without SA 493 or SA 672 .....	8
6. Installation in cars with SA 493 or SA 672 .....	10
7. Concluding work and coding .....	12

## 1. Parts list

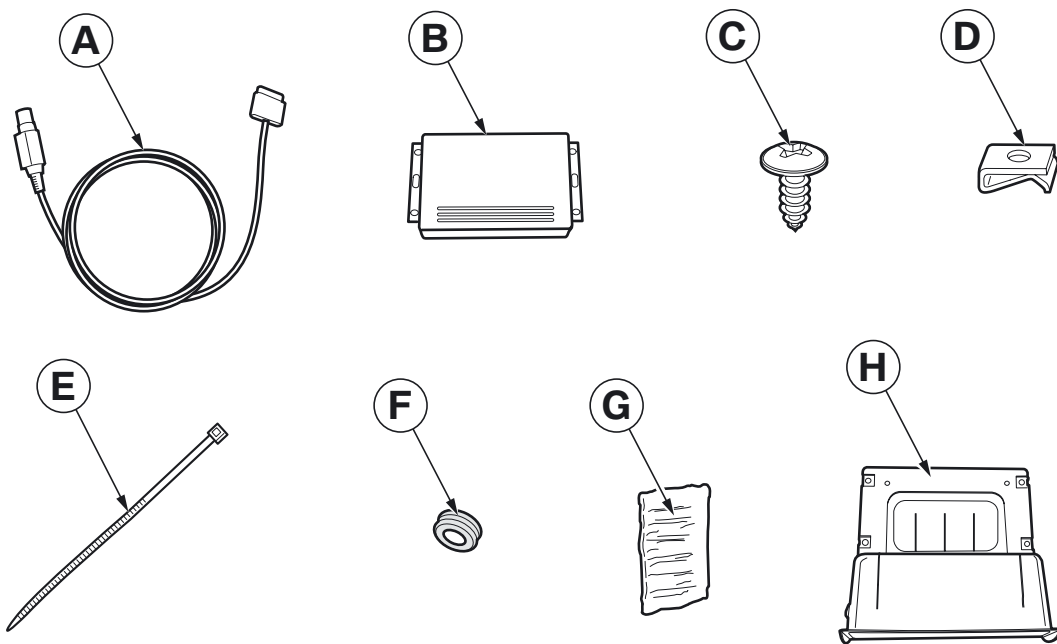

R56 0234 Z

### Legend

- A** Connection cable
- B** Interface
- C** Self-tapping screw (2x)
- D** Speed nut (2x)
- E** Cable tie (10x)
- F** Grommet
- G** Insulating pad (4x)
- H** iPod interface storage tray

## 2. Preparatory work

	<b>TIS No.</b>
Conduct a brief test	---
Disconnect the negative pole of the battery	12 00 ...
<b>The following components must be removed first of all</b>	
Décor trim on right of instrument panel (cars without SA 672 (CD changer preparation) and without SA 493 (storage package) only)	51 45 380
Décor trim on left of instrument panel	51 45 370
Trim for the dashboard at the bottom	51 45 180
Trim for the centre console at the side	51 45 ...
Instrument cover	51 45 435
Centre console trim	51 16 160
Instrument cluster complete	62 10 125
<b>Additionally for cars with SA 672 (CD changer)</b>	
CD changer (no longer required)	65 11 072
<b>Additionally for cars with SA 493 (storage package)</b>	
Storage tray (no longer required)	51 45 ...

### 3. Connection diagram

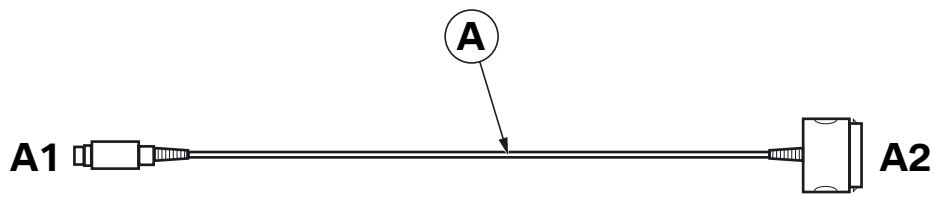

R56 0080 Z

Branch/ item	Designation	Signal	Cable colour/ cross-section	Connection location in car	Abbreviation/ slot
A	Connection cable	---	---	---	---
A1	Black 12-pin socket casing	---	---	To interface B	---
A2	iPod connection plug	---	---	On iPod	---

## 4. Installation and cabling diagram

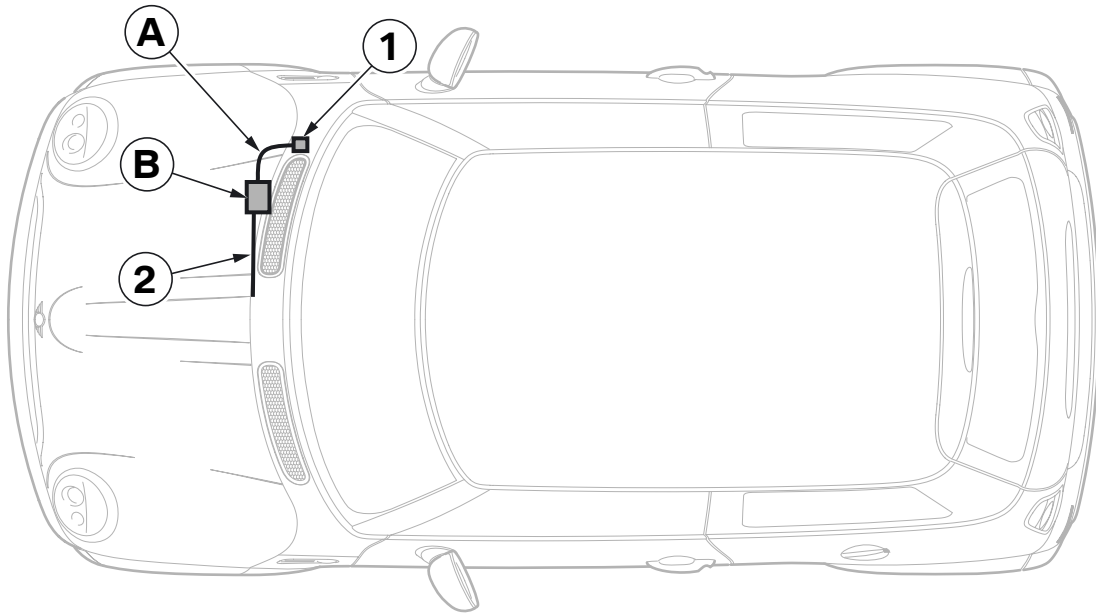

R56 0081 Z

### Legend

- A** Connection cable
- B** Interface
  
- 1** iPod connection plug **A2**
- 2** CD changer connection cable

## 5. Installation in cars without SA 493 or SA 672

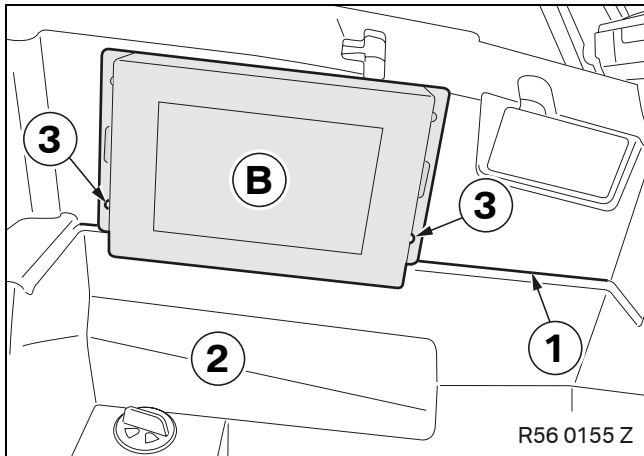

Hold interface **B** against the edge (1) in the glove box (2).  
Mark both holes (3) on the glove box (1) and drill through with a 5 mm twist drill bit.

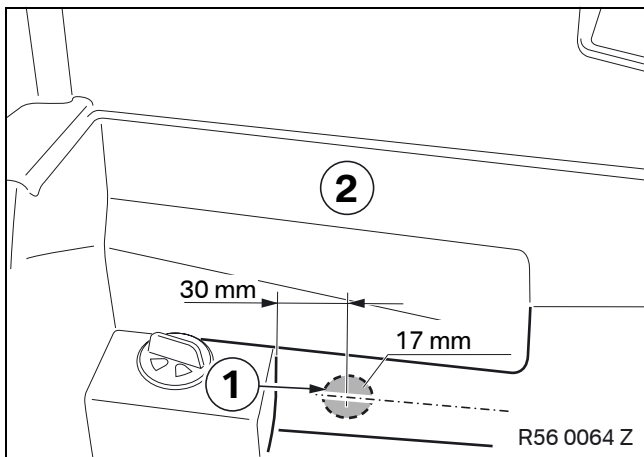

Drill a hole (1) in the glove compartment (2) using a 17 mm step drill bit according to the dimensions shown.

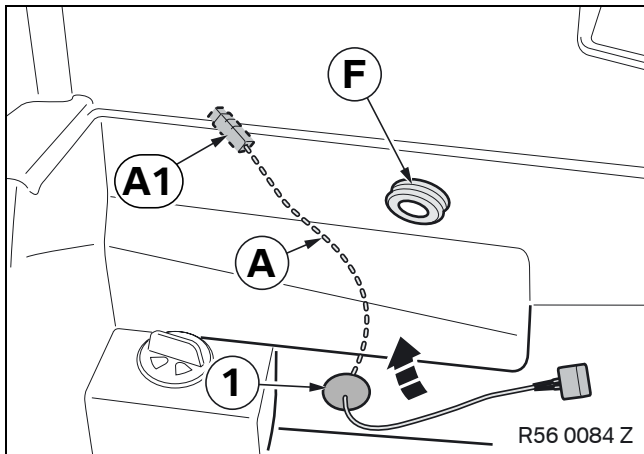

Install connection cable **A** as follows:

- Feed branch **A1** through the hole (1)
- Push grommet **F** onto branch **A1** and insert it into the hole (1)

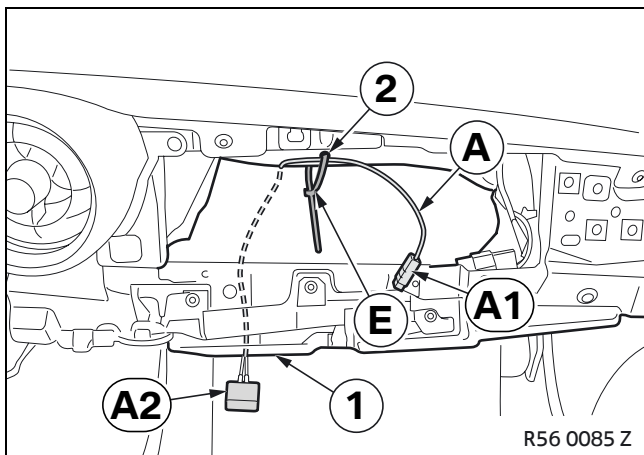

Pull branch **A1** of the connection cable **A** inwards until iPod connection plug **A2** is just above the outer edge (1) of the glovebox.

Use cable tie **E** to secure connection cable **A** to the hole (2) in the dashboard support to act as strain relief.

## 5. Installation in cars without SA 493 or SA 672

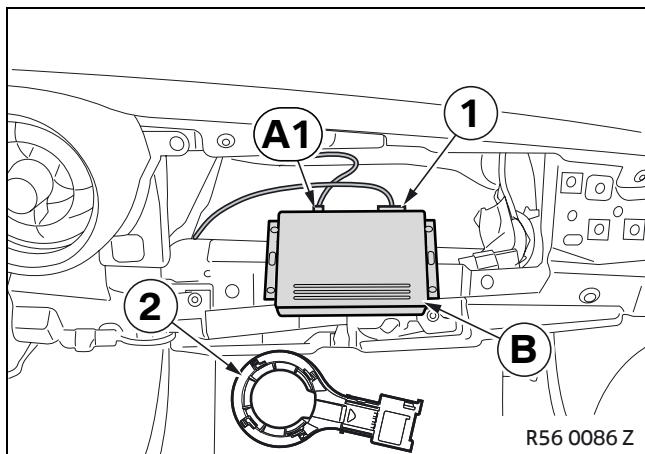

▶ On cars with SA 694 (CD changer preparation), the tied-back CD changer plug (1) must be released and the shorting plug (2) removed. ◀

Route the CD changer plug (1) to the interface **B** and plug it in.

Route branch **A1** to interface **B** and connect it.

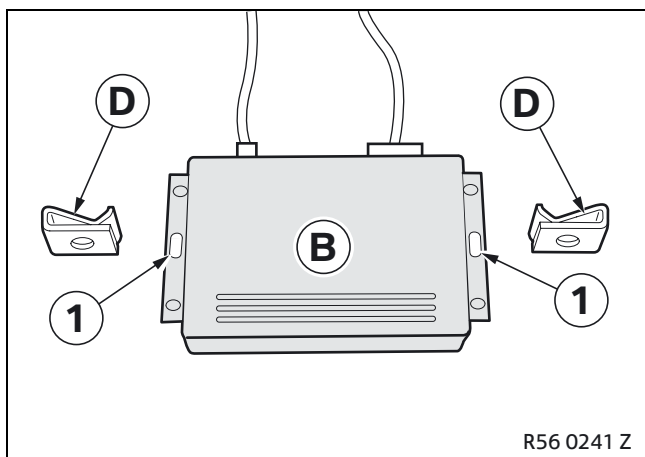

Fit speed nuts **D** to extended holes (1) on the interface **B**.

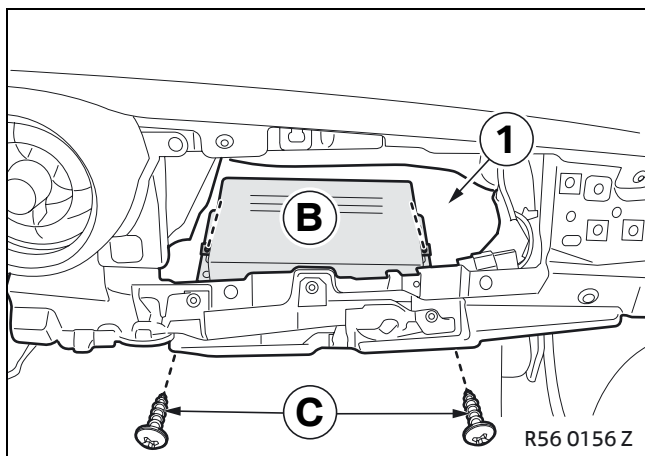

Attach interface **B** to the glove box (1) using self-tapping screws **C**.

## 6. Installation in cars with SA 493 or SA 672

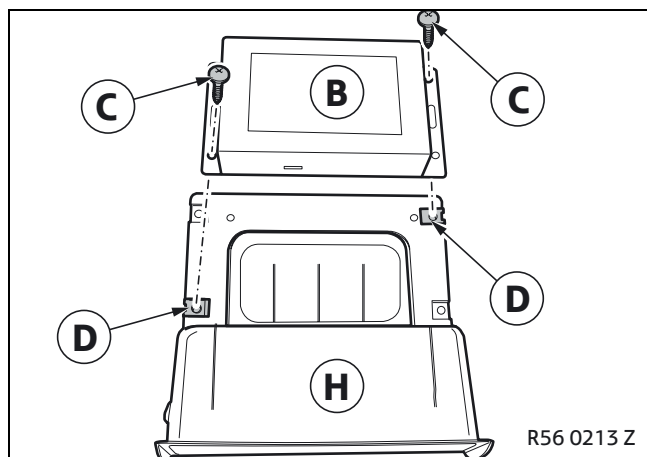

Fit speed nuts **D** to iPod interface storage tray **H**.

Attach interface **B** to the iPod interface storage **H** using self-tapping screws **C**.

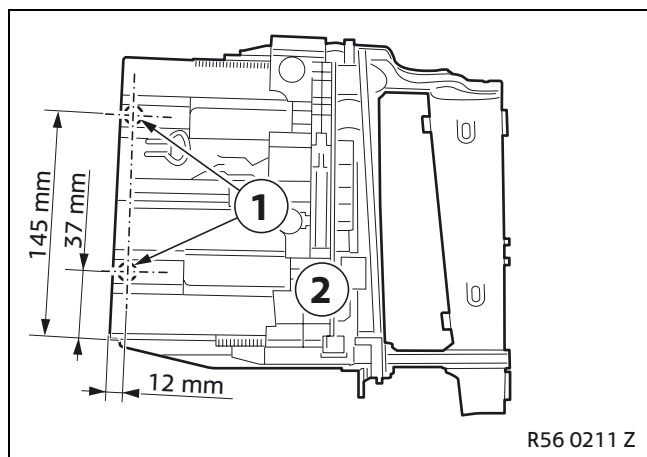

Mark the holes (1) according to the dimensions shown on the CD changer/storage tray holder (2) and drill through with a 5 mm twist drill bit.

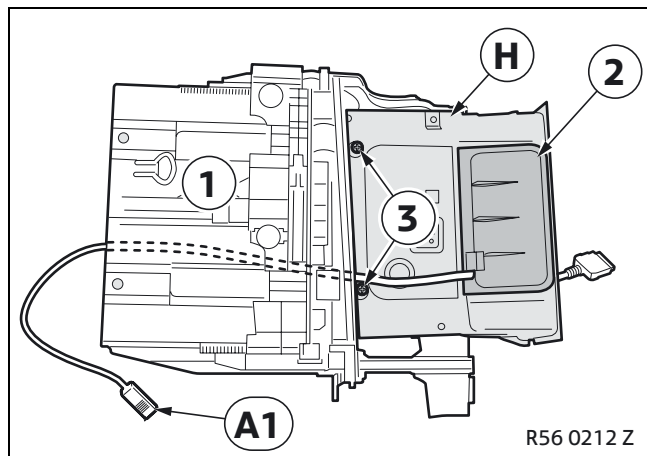

Remove screws (3) from iPod interface storage tray **H** (required later).

Guide branch **A1** through the opening in the iPod interface storage tray **H** and CD changer/storage tray holder (1) and fold lid (2) over.

Insert iPod interface storage tray **H** in CD changer/storage tray holder (1).

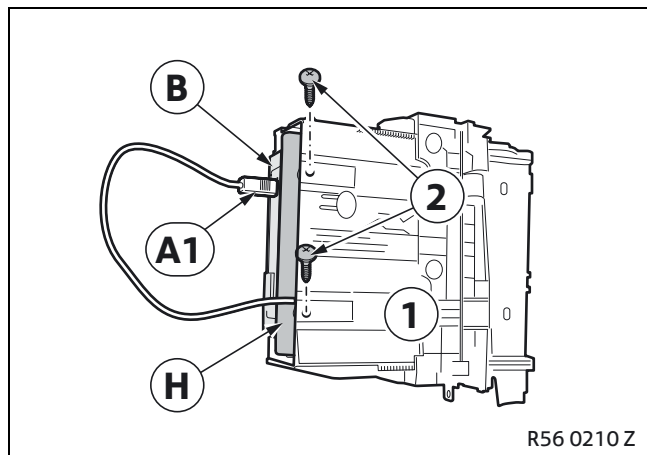

Attach CD changer/storage tray holder (1) to iPod interface storage tray **H** using screws previously removed (2).

Connect branch **A1** to interface **B**.

## 6. Installation in cars with SA 493 or SA 672

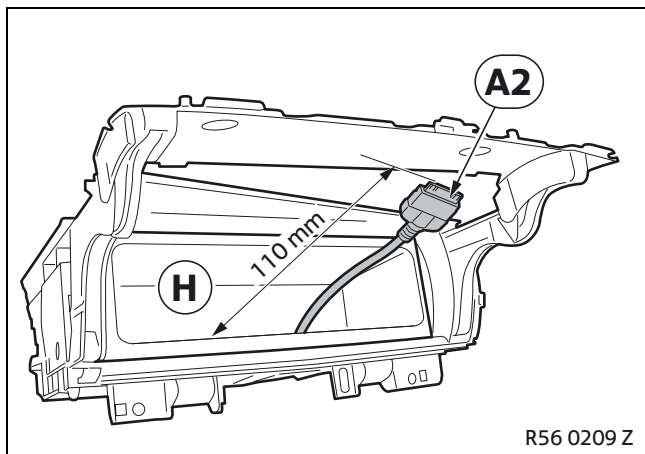

Pull branch **A2** out of the iPod interface storage tray **H** as far as dimension shown.

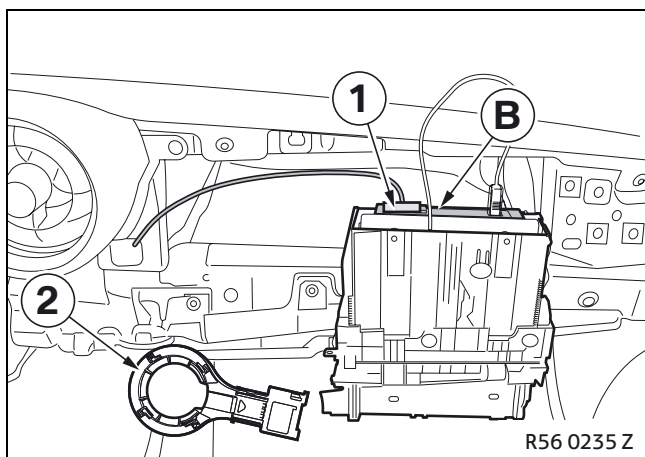

▶ On cars with SA 694 (CD changer preparation), the tied-back CD changer plug (1) must be released and the shoring plug (2) removed. ◀

Route the CD changer plug (1) to the interface **B** and plug it in.

## 7. Concluding work and coding

This retrofit system requires coding.

- Connect the battery
- Encode/program the retrofit with SSS (software service station) via the **Retrofit** path
- Conduct a brief test
- Conduct a function test
- Re-fit the car components as required