

Original MINI Accessories. Installation Instructions.



Xenon headlights retrofit (downloaded from MotoringFile.com)

MINI ONE and COOPER (R50) built after 09/03

MINI COOPER S (R53) built after 09/03

MINI Convertible (R52)

Retrofit kit no.: 61 61 0 395 398 Xenon Light Retrofit Kit

Installation time

The installation time is approx. 6.5 hours, but may vary depending on the condition of the car and the equipment in it.

Important information

These installation instructions are primarily designed for use within the MINI dealership organisation and by authorised MINI service companies.

In any event, the target group for these installation instructions is specialist personnel trained on MINI cars with the appropriate specialist knowledge.

All work must be completed using the latest MINI repair manuals, circuit diagrams, servicing manuals and work instructions, in a rational order, using the prescribed tools (special tools) and observing current health and safety regulations.

To avoid unnecessary extra work and/or costs, if any installation or function problem occurs, after a brief troubleshooting session (approx. 0.5 hours), please contact the following:

- 1. Either your national subsidiary or your regional office, or**
- 2. The Support team via the Aftersales Assistance Portal (ASAP), using the optional technical parts support application.**

Specify the chassis number and the part number of the installed retrofit kit and give a precise description of the problem.

Do not archive the hard copy of these installation instructions since daily updates are made by ASAP!

All pictures show LHD cars; proceed accordingly on RHD cars.

Pictograms:



Denotes instructions that draw your attention to special features.

- ◀ Denotes the end of the instruction or other text.

Subject to technical modifications!

Installation information

Ensure that the cables/lines are not kinked or damaged as you install them in the car. Costs incurred as a result of this will not be reimbursed by BMW AG.

Additional cables/lines that you install must be secured with cable ties.

If the specified PIN chambers are occupied, bridges, double crimps or twin-lead terminals must be used.

After the installation work the retrofit must be programmed / coded using SSS (software service station) via the **Retrofit** path.

Ordering instructions

If the car is not fitted with SA 502 (headlight washing system), it must be retrofitted (see EPC for part number and further details).

The xenon headlights **C** and **D** are not included in the retrofit kit and must be ordered separately (see EPC for part number and further details).

The heated spray jets are not supplied in the retrofit kit and must be ordered separately (see EPC for part number and details).

Special tools required

None

Contents

Section	Page
1. Parts overview	4
2. Preparatory work	5
3. Installation and cabling diagram for headlight adjustment control retrofit wiring harness . . .	6
4. Installation and cabling diagram for headlight retrofit wiring harness	7
5. Headlight adjustment control retrofit wiring harness connections diagram	8
6. Headlight retrofit wiring harness connection diagram	9
7. To install the xenon headlights	11
8. To install the front load sensor	12
9. To install the rear load sensor.	13
10. To install the headlight adjustment control retrofit wiring harness.	14
11. To install the headlight retrofit wiring harness.	16
12. Concluding work and coding	20
13. Headlight adjustment control retrofit wiring harness circuit diagram	21
14. Headlight retrofit wiring harness circuit diagram (R50/R53 cars only)	22
15. Headlight retrofit wiring harness circuit diagram (R52 cars only)	24

1. Parts overview

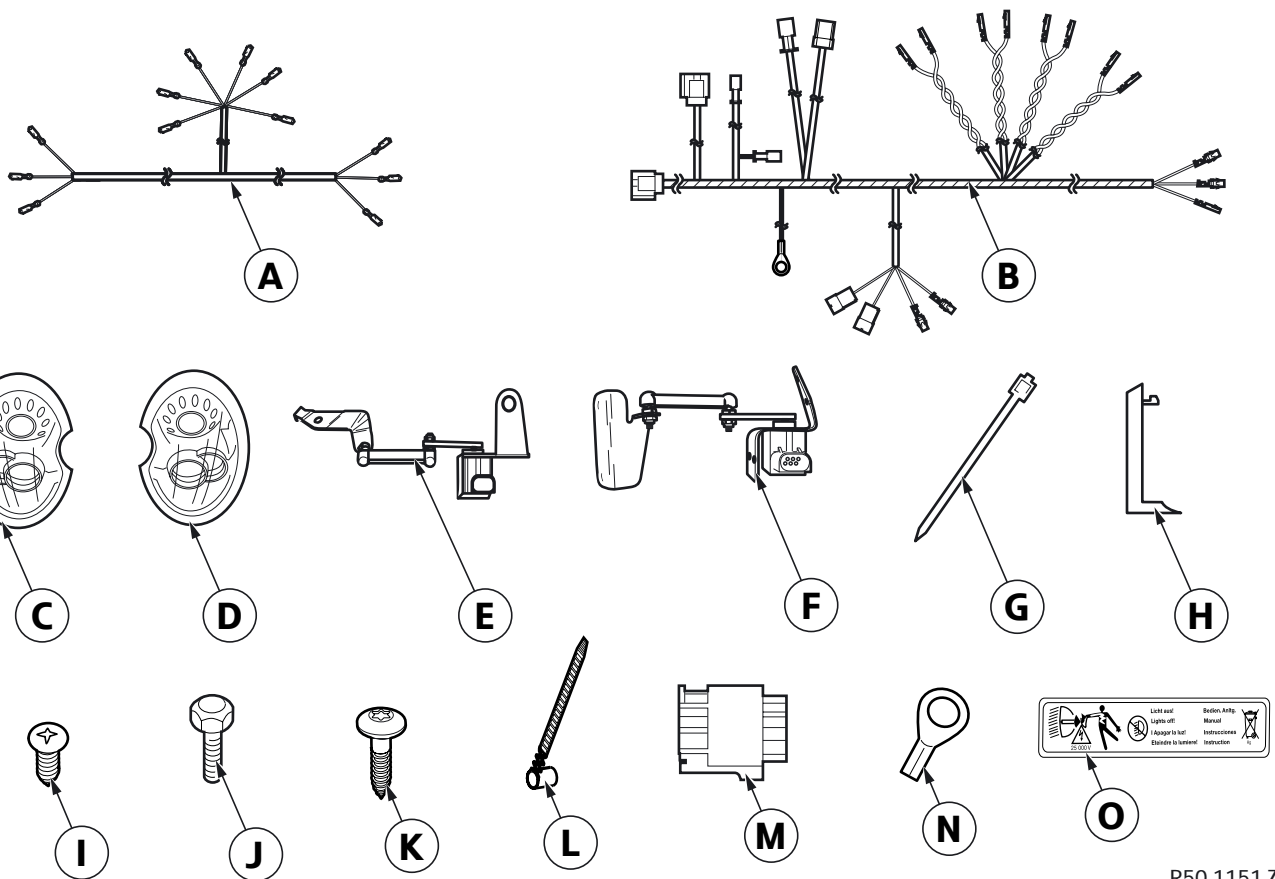

Legend

- A Headlight adjustment control retrofit wiring harness
- B Headlight retrofit wiring harness
- C Right xenon headlight (not supplied with the retrofit kit)
- D Left xenon headlight (not supplied with the retrofit kit)
- E Load sensor, front
- F Load sensor, rear
- G Cable ties (20x)
- H Manual headlight adjustment control trim
- I Fillister head screw (4x)
- J Hexagonal screw M6 x 16 mm (3x)
- K Pan head screws M8 x 21 mm (4x)
- L Cable tie
- M 6-pin socket casing (2x)
- N Eyelet
- O Xenon light sticker

2. Preparatory work

	TIS No.
Conduct a brief test	---
Disconnect negative pole of battery	12 00 ...
The following components must be removed first of all	
Remove the left oddments box	51 16 392
Right glove compartment	51 16 860
Left drive shaft	31 60 003
Door sill strip on both sides	51 47 510
Front wheel arch trim on both sides	51 71 540
Headlights on both sides	63 12 808
Bonnet trim	51 48 501
Additional right indicator	63 13 700
Release the base module	61 35 510
Release fuse holder	61 35 000
Cover behind the hydraulic unit	---
Rear seat	52 20 010
Headlight adjustment switch (no longer required)	61 31 072
R53 cars only	
Rear silencer	18 12 533

3. Installation and cabling diagram for headlight adjustment control retrofit wiring harness

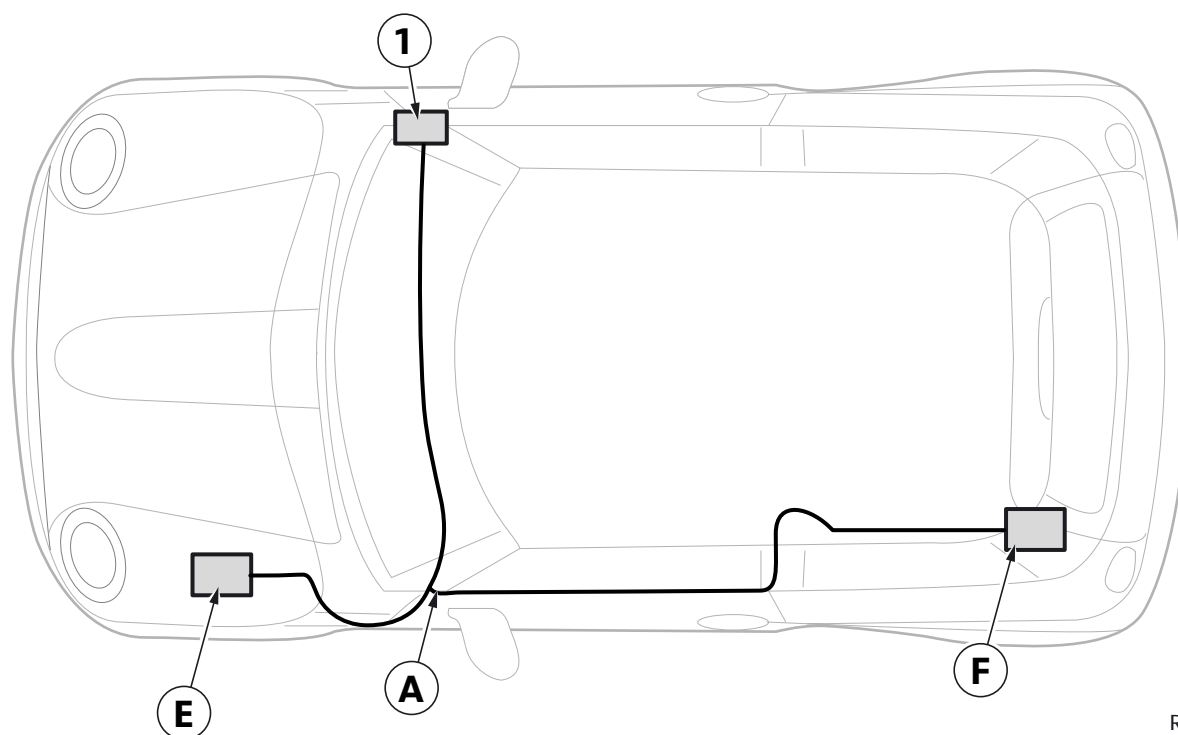

R50 1152 Z

Legend

- A Headlight adjustment control retrofit wiring harness
- E Load sensor, front
- F Load sensor, rear

- 1 Base module

4. Installation and cabling diagram for headlight retrofit wiring harness

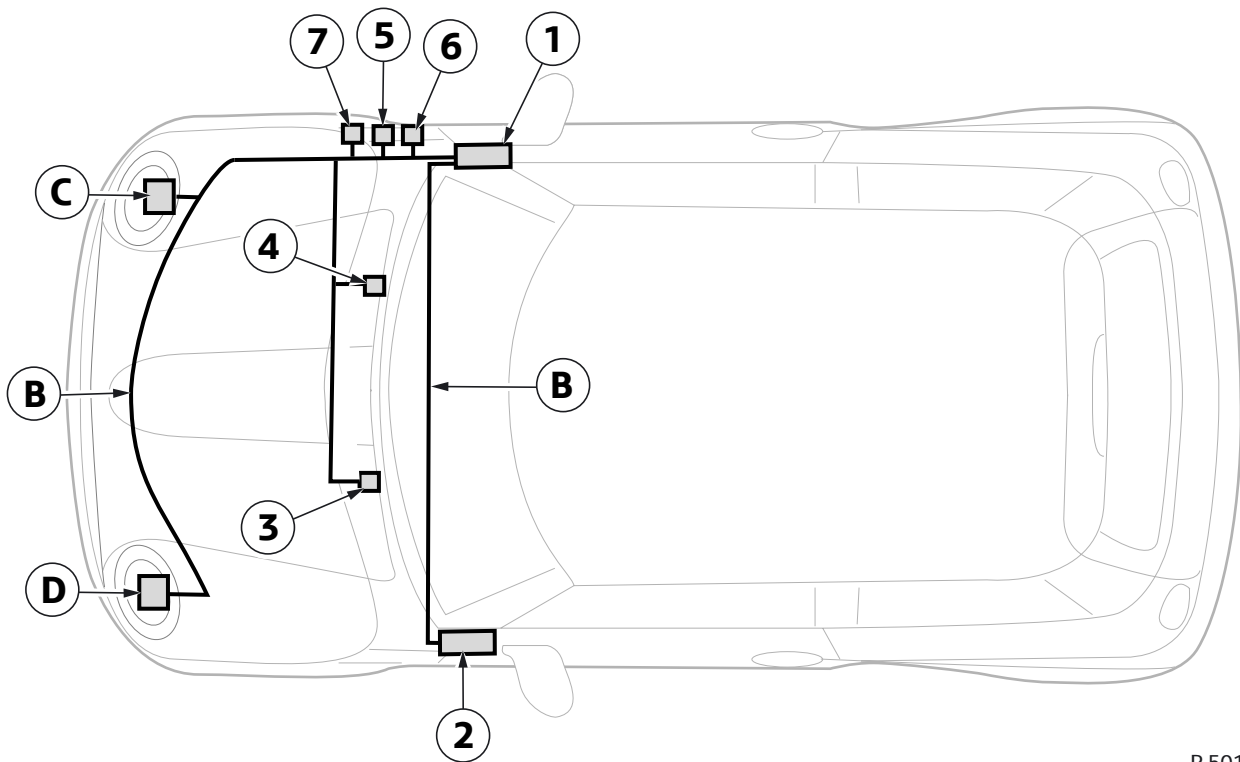

R 501460 Z

Legend

- B** Headlight retrofit wiring harness
- C** Xenon headlight, right
- D** Xenon headlight, left

- 1** Base module
- 2** Fuse holder
- 3** Heated spray jet, left
- 4** Heated spray jet, right
- 5** Washing water pump
- 6** Additional indicator light, front right
- 7** Washer fluid sensor (cars built after 01/05 only)

5. Headlight adjustment control retrofit wiring harness connections diagram

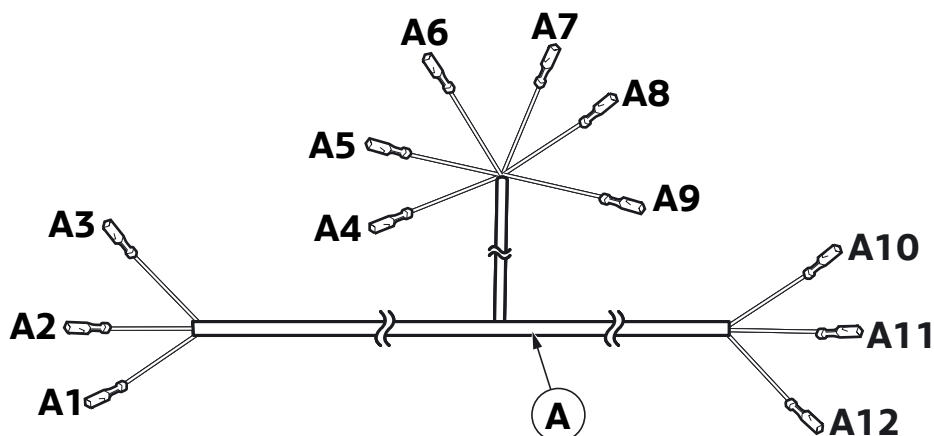

R50 1147 Z

Item	Designation	Signal	Cable color / Cross-section	Connection location in the car	Abbreviation / Slot
A	Headlight adjustment control retrofit wiring harness	---	---	---	---
A1	Socket contact	HSSV	GR/GN 0.5 mm ²	To front load sensor E	X18032 PIN 4
A2	Socket contact	HSGV	GR/WS 0.5 mm ²	To front load sensor E	X18032 PIN 1
A3	Socket contact	HSPV	GR/BR 0.5 mm ²	To front load sensor E	X18032 PIN 5
A4	Socket contact	HSSV	GR/GN 0.5 mm ²	To SW 54-pin socket casing on base module	X253 PIN 14
A5	Socket contact	HSGV	GR/WS 0.5 mm ²	To SW 54-pin socket casing on base module	X253 PIN 49
A6	Socket contact	HSPV	GR/BR 0.5 mm ²	To SW 54-pin socket casing on base module	X253 PIN 13
A7	Socket contact	HSSH	SW/GN 0.5 mm ²	To SW 54-pin socket casing on base module	X253 PIN 32
A8	Socket contact	HSGH	SW/WS 0.5 mm ²	To SW 54-pin socket casing on base module	X253 PIN 48
A9	Socket contact	HSPH	SW/GR 0.5 mm ²	To SW 54-pin socket casing on base module	X253 PIN 31
A10	Socket contact	HSSH	SW/GN 0.5 mm ²	To rear load sensor F	X13251 PIN 4
A11	Socket contact	HSGH	SW/WS 0.5 mm ²	To rear load sensor F	X13251 PIN 1
A12	Socket contact	HSPH	SW/GR 0.5 mm ²	To rear load sensor F	X13251 PIN 5

6. Headlight retrofit wiring harness connection diagram

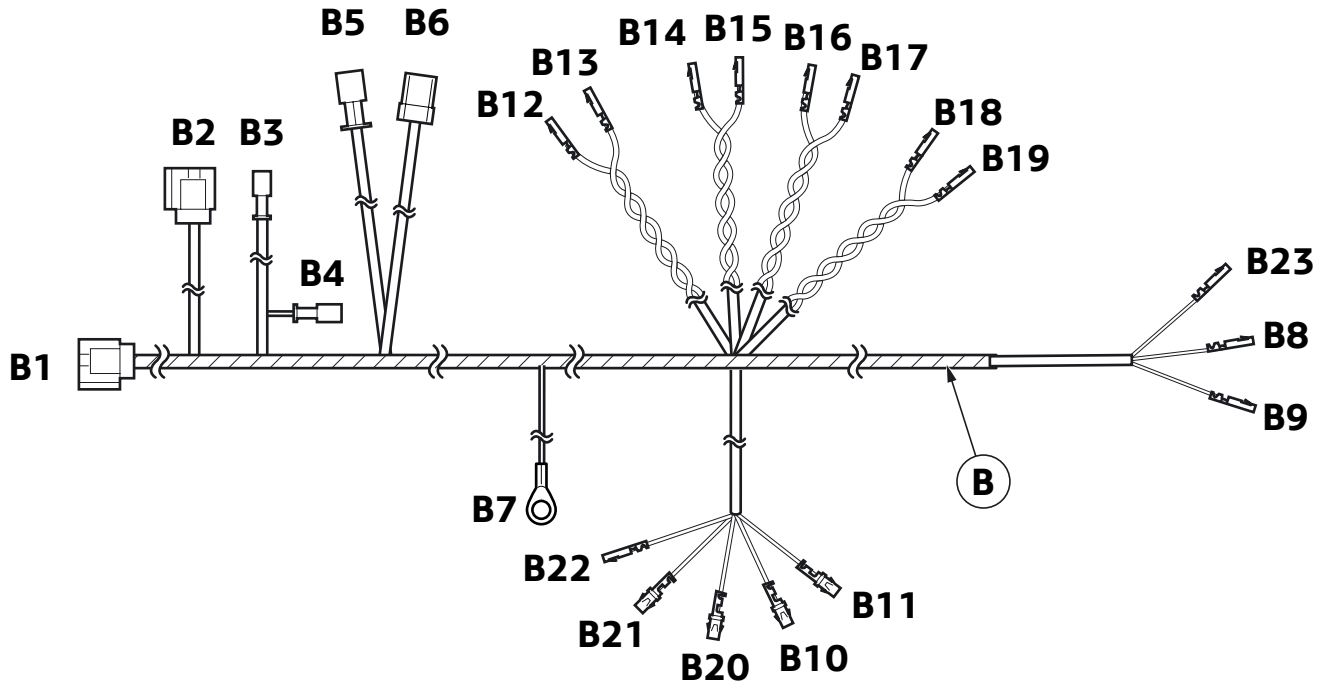

R50 1150 Z

Item	Designation	Signal	Cable color / Cross-section	Connection location in the car	Abbreviation / Slot
B	Headlight retrofit wiring harness	---	---	---	---
B1	SW 9-pin socket casing	---	---	To xenon headlight, left D	X130
B2	SW 9-pin socket casing	---	---	To xenon headlight, right C	X135
B3	SW 2-pin socket casing	---	---	To heated spray jet, left	X105
B4	SW 2-pin socket casing	---	---	To heated spray jet, right	X106
B5	SW 2-pin socket casing	---	---	To additional indicator light front right	X390
B6	SW 2-pin socket casing	---	---	To washing water pump front right	X107
B7	Eyelets	Terminal 31	BR	To earth post connection on right side skirt	X151
B8	Socket contact	MLSL	SW/BR 1.5 mm ²	R50/R53 cars only To washing water pump relay K119 R52 cars only To washing water pump relay K5	X1594, PIN 6 X1594, PIN 2
B9	Socket contact	MLSL2	SW/BL 1.5 mm ²	R50/R53 cars only To washing water pump relay K119 R52 cars only To earth post in the left side skirt	X1594, PIN 1 X1108
B10	Round contact	Terminal 56AL	GN/WS 2.5 mm ²	To GN 20-pin socket casing on base module	X332 PIN 9
B11	Round contact	Terminal 56BL	GN/GE 1.5 mm ²	To GN 20-pin socket casing on base module	X332 PIN 15
B12	Socket contact	Q12L	GE/RT 0.5 mm ²	To natural-colored 54-pin socket casing on base module	X254 PIN 20
B13	Socket contact	Q11L	GE/BR 0.5 mm ²	To natural-colored 54-pin socket casing on base module	X254 PIN 38
B14	Socket contact	Q22L	BL/RT 0.5 mm ²	To natural-colored 54-pin socket casing on base module	X254 PIN 1
B15	Socket contact	Q21L	BL/BR 0.5 mm ²	To natural-colored 54-pin socket casing on base module	X254 PIN 21

6. Headlight retrofit wiring harness connection diagram

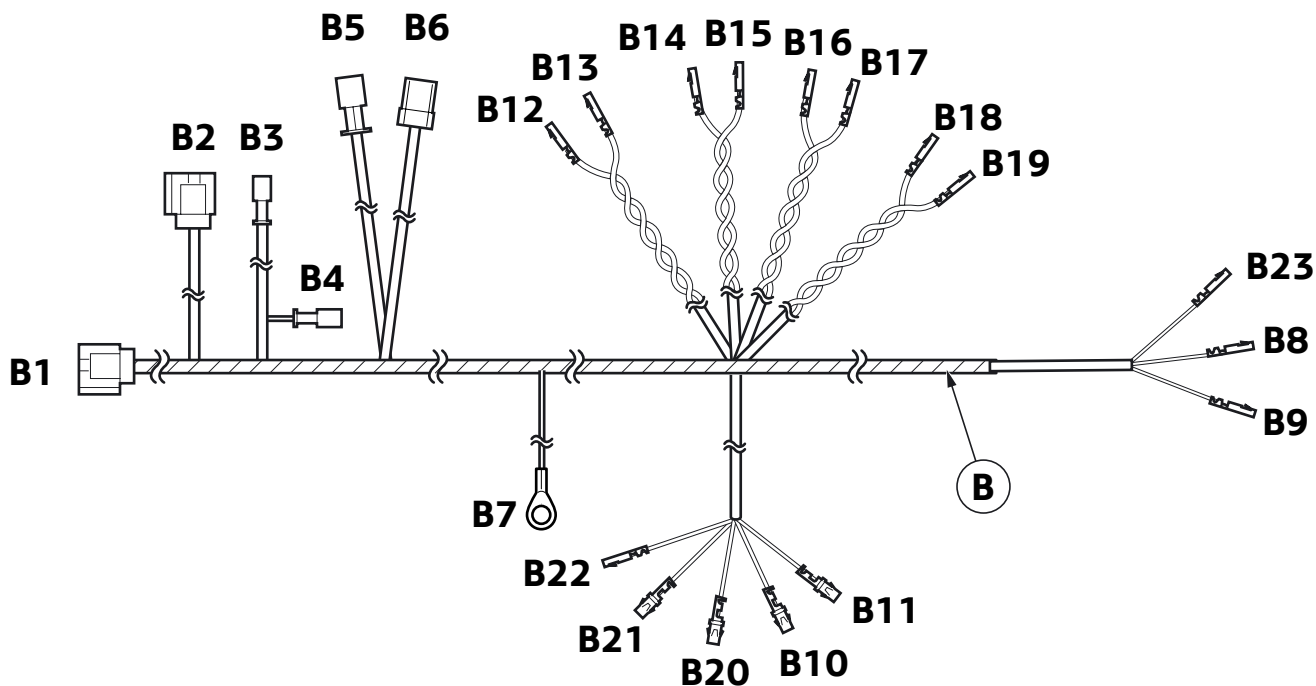

R50 1150 Z

Item	Designation	Signal	Cable color / Cross-section	Connection location in the car	Abbreviation / Slot
B16	Socket contact	Q11R	GE/SW 0.5 mm ²	To natural-colored 54-pin socket casing on base module	X254 PIN 37
B17	Socket contact	Q12R	GE/BR 0.5 mm ²	To natural-colored 54-pin socket casing on base module	X254 PIN 2
B18	Socket contact	Q21R	BL/SW 0.5 mm ²	To natural-colored 54-pin socket casing on base module	X254 PIN 3
B19	Socket contact	Q22R	BL/BR 0.5 mm ²	To natural-colored 54-pin socket casing on base module	X254 PIN 19
B20	Round contact	Terminal 56AR	WS/BL 2.5 mm ²	To GN 20-pin socket casing on base module	X332 PIN 13
B21	Round contact	Terminal 56BR	GE/BL 1.5 mm ²	To GN 20-pin socket casing on base module	X332 PIN 19
B22	Socket contact	Terminal 49ZR	BL/GE 0.5 mm ²	To natural-colored 54-pin socket casing on base module	X254 PIN 13
B23	Socket contact	Terminal 15	GN/GE 0.75 mm ²	Cars built before 09/05 only To 12-pin natural-colored socket casing in fuse holder II Cars built after 09/05 only To 12-pin natural-colored socket casing in fuse holder II	X10204 PIN 10 X10204 PIN 4

7. To install the xenon headlights

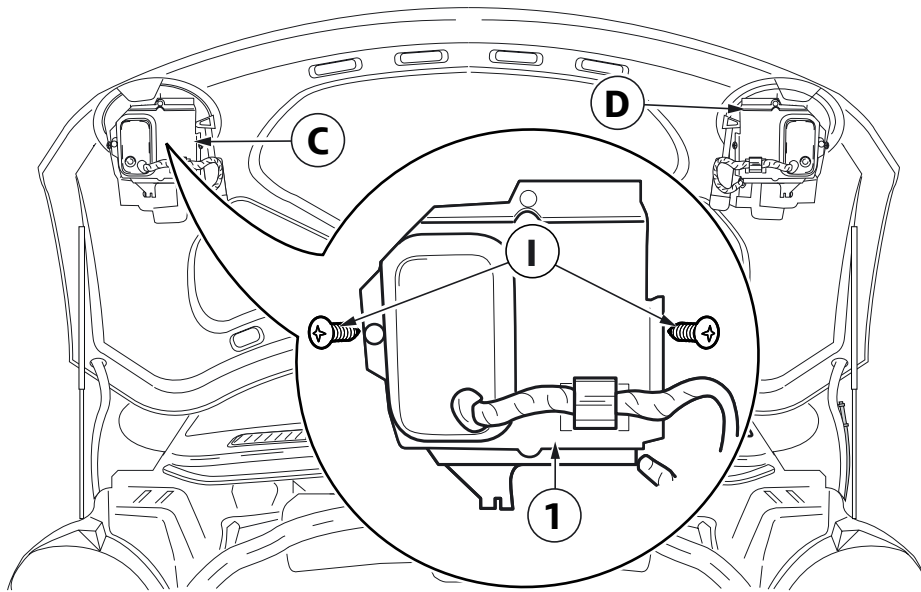

R50 1154 Z

Install the Xenon headlights **C** and **D** as described in TIS-RA 63 12 808.

Secure the xenon headlight control modules (1) with two fillister head self-tapping screws **L** on each side.

8. To install the front load sensor

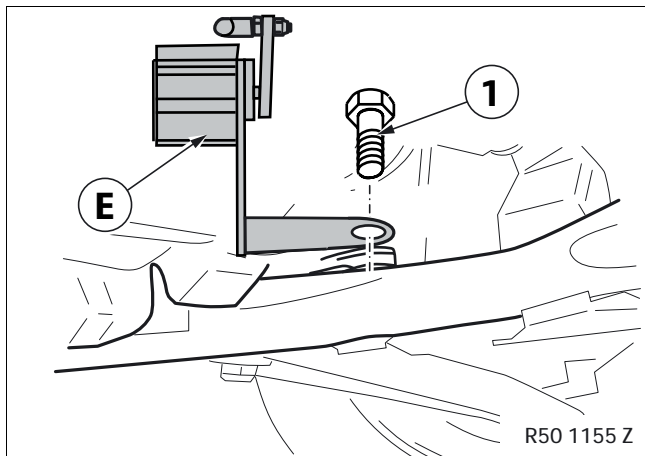

Unscrew the front hexagonal screw (1) which secures the inner ball joint to the front axle mounting.

Install the front load sensor **E** using the hexagonal screw (1).

Tighten the screw (1) with a torque of 100 Nm.

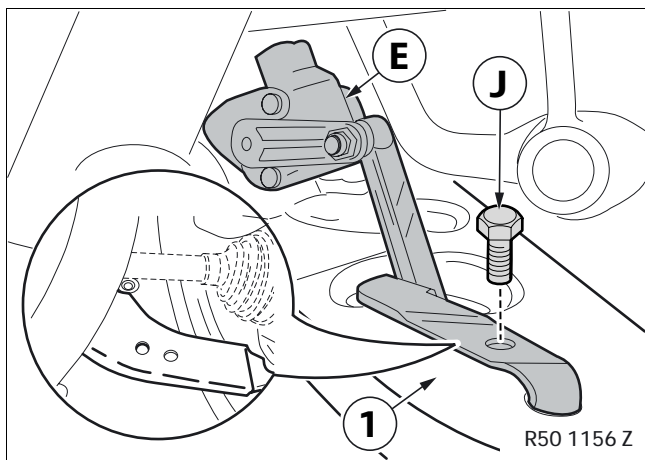

Secure the load sensor **E** to the control arm (1) using hexagonal screw **J**.

9. To install the rear load sensor

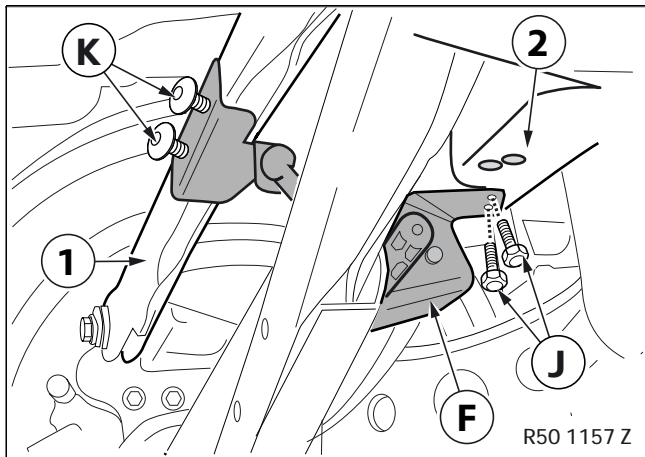



 The rear load sensor **F** must be installed above the brake line. ◀

Secure the rear load sensor **F** to the top control arm (1) using pan head screws **K**.

Secure the load sensor **F** to the axle mounting (2) using hexagonal screws **J**.

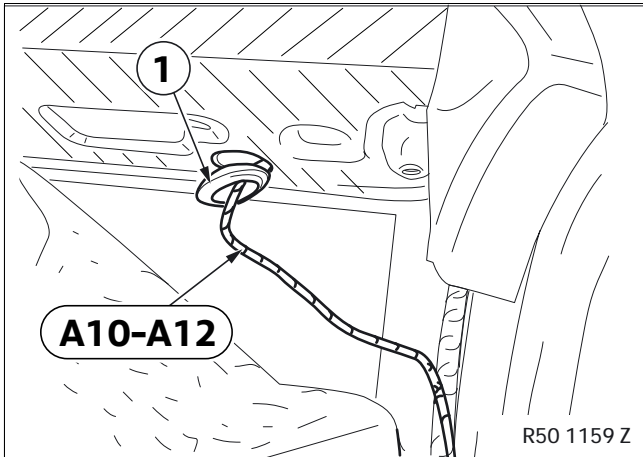
10. To install the headlight adjustment control retrofit wiring harness



 The figure shows the rubber grommet (1) in the rear left footwell. ◀

Route branches **A10-A12** through the rubber grommet (1) to the rear load sensor **F**.

Seal the rubber grommet (1).

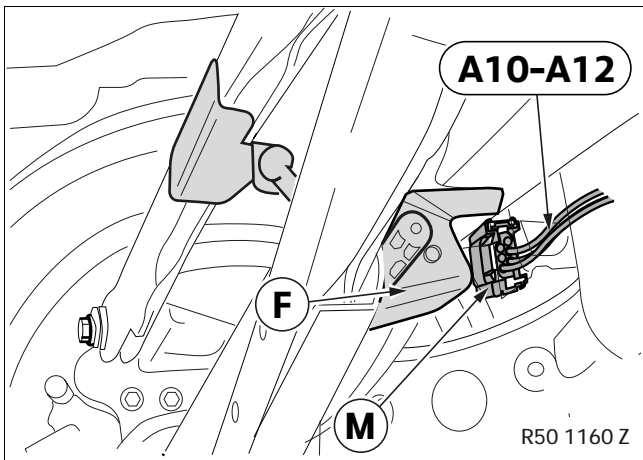

Connect branches **A10 – A12** to the 6-pin socket casing **M** as follows:

- Branch **A10**, SW/GN cable, to PIN 4.
- Branch **A11**, SW/WS cable, to PIN 1.
- Branch **A12**, SW/GR cable, to PIN 5.

Connect socket casing **M** to the rear load sensor **F**.

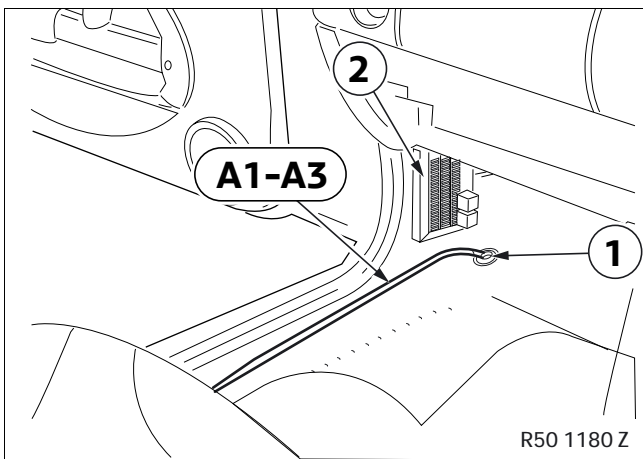

R50/R53 cars built before 07/04 only

Route branches **A1-A3** through the rubber grommet (1) under the fuse box II (2) to the outside.

Seal the rubber grommet (1).

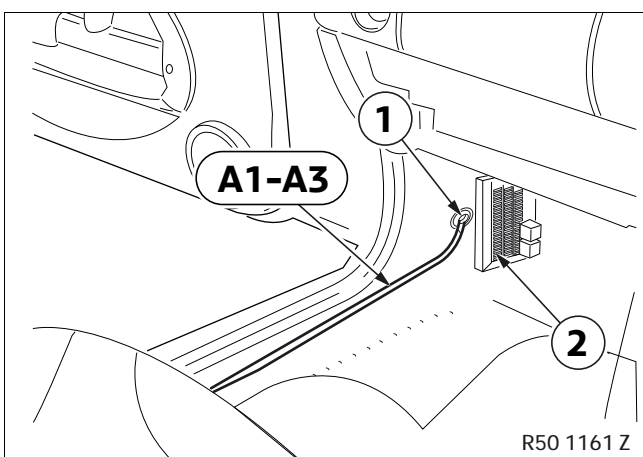

R52 cars and R50/R53 cars built after 07/04 only

Route branches **A1-A3** through the rubber grommet (1) behind the fuse box II (2) to the outside.

Seal the rubber grommet (1).

10. To install the headlight adjustment control retrofit wiring harness

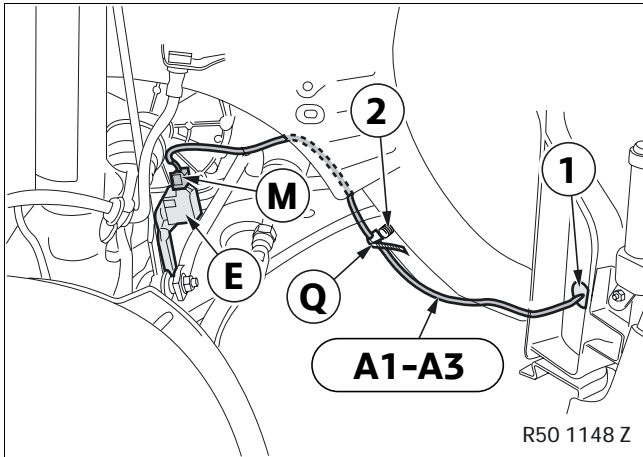

All cars

Route branches **A1-A3** through the rubber grommet (1) to the front load sensor **E**.

Attach a cable tie **Q** to the stud bolt (2) and secure the cable.

Connect branches **A1 - A3** to the 6-pin socket casing **M** as follows:

- Branch **A1**, GR/GN cable, to PIN 4.
- Branch **A2**, GR/WS cable, to PIN 1.
- Branch **A31**, GR/BR cable, to PIN 5.

Connect socket casing **M** to the load sensor **E**.

Route branches **A4 - A9** to the base module (1).

Connect branches **A4 - A9** to the 54-pin SW plug **X253** as follows:

- Branch **A4**, GR/GN cable, to PIN 14.
- Branch **A5**, GR/WS cable, to PIN 49.
- Branch **A6**, GR/BR cable, to PIN 13.
- Branch **A7**, SW/GN cable, to PIN 32.
- Branch **A8**, SW/WS cable, to PIN 48.
- Branch **A9**, SW/GR cable, to PIN 31.

Connect plug **X253** to the base module (1).

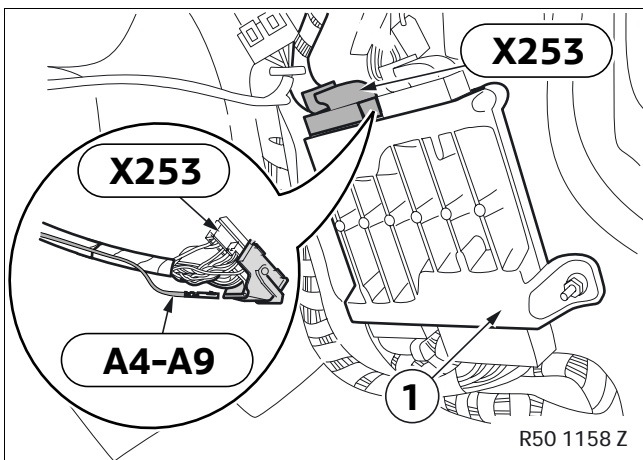

11. To install the headlight retrofit wiring harness

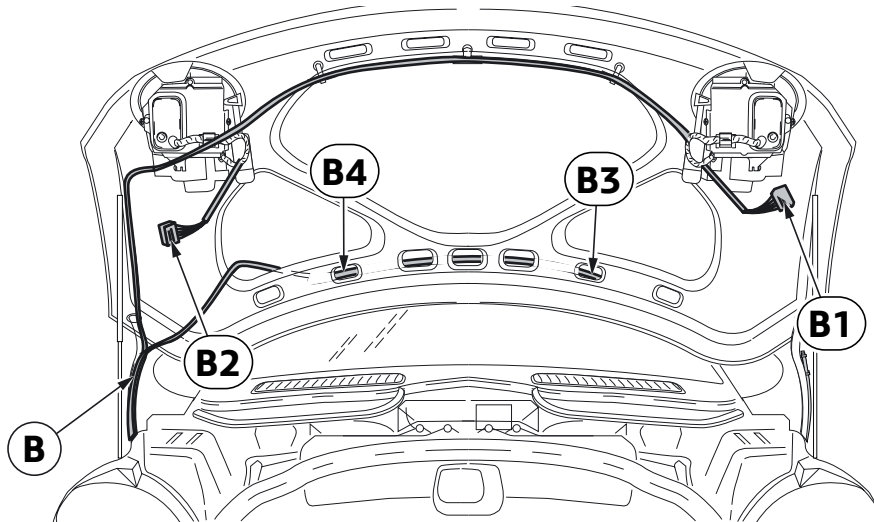

R50 1164 Z

Remove the existing headlight wiring harness as far as the rubber grommet behind the ABS hydraulic unit (the existing wiring harness will later be cut and removed).

Route the headlight wiring harness **B** along the route of the old headlight wiring harness and connect it as follows:

▶ If no heated spray jets are fitted, insulate branches **B3** and **B4** and tie them back to a suitable point. ◀

- Branch **B1** to plug **X130** on the left xenon headlight **D**
- Branch **B2** to plug **X135** on the right xenon headlight **C**
- Branch **B3** to plug **X105** to the heated spray jet, left
- Branch **B4** to plug **X106** to the heated spray jet, right

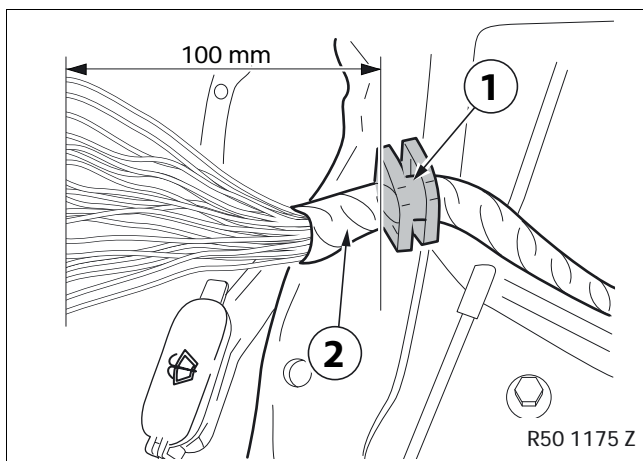

Cars built before 01/05 only (without washer fluid sensor)

Cut off the old wiring harness (2) in front of the rubber grommet (1) and insulate it so that it is watertight.

Tie back the old wiring harness (2) at a suitable point.

Cars built after 01/05 only (with washer fluid sensor)

▶ Do not cut cables of the washer fluid sensor, SW/GE and BR cable. ◀

▶ The figure shows the rubber grommet (1) behind the ABS hydraulic unit. ◀

Carefully cut open the rubber grommet (1).

Route branches **B7 – B23** through the rubber grommet (1) into the interior.

Seal the rubber grommet (1).

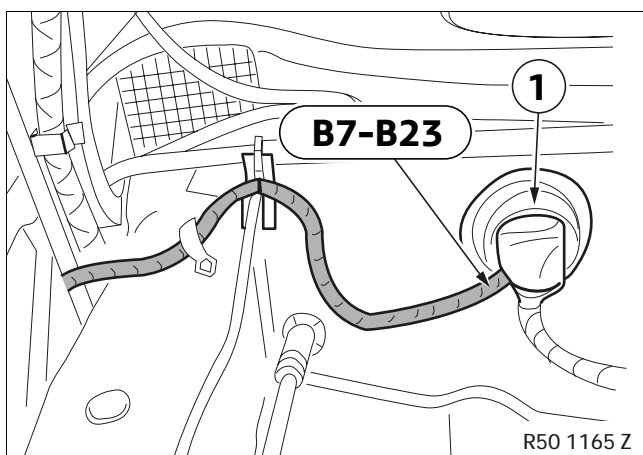

11. To install the headlight retrofit wiring harness

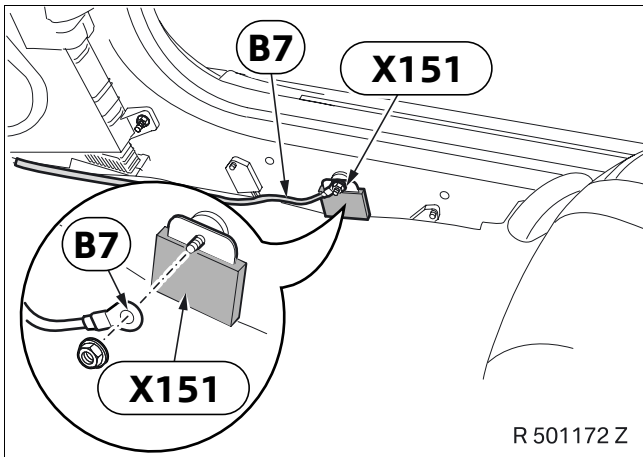

Route branch **B7** to the earth post **X151** and secure it.

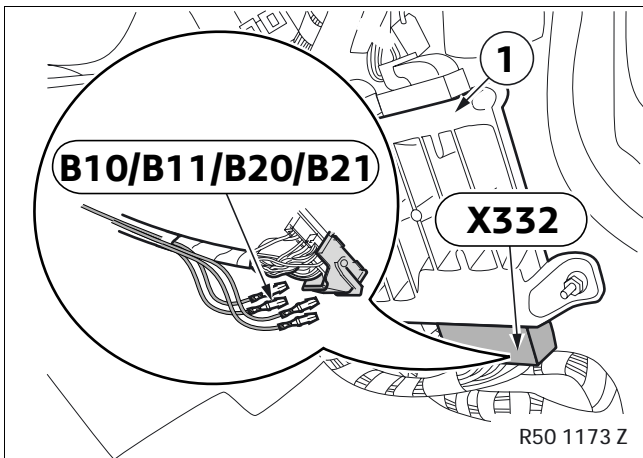

▶ Disconnect the existing cables, insulate them and tie them back. ◀

Connect branches **B10**, **B11**, **B20** and **B21** to the 20-pin GN plug **X332** on the base module (1) as follows:

- Branch **B10**, GN/SW cable, to PIN 9
- Branch **B11**, GN/GE cable, to PIN 15
- Branch **B20**, WS/BL cable, to PIN 13
- Branch **B21**, GE/BL cable, to PIN 19

Connect plug **X332** to the base module (1).

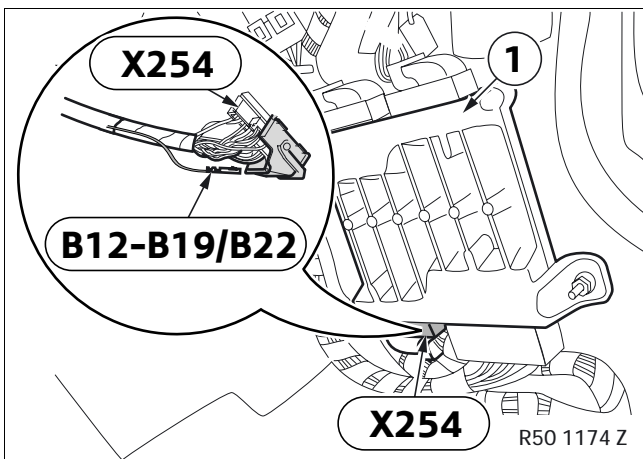

▶ Disconnect the old cables, insulate them and tie them back. ◀

Connect branches **B12 - B19** and **B22** to the 54-pin natural-colored plug **X254** on the base module (1) as follows:

- Branch **B12**, GE/RT cable, to PIN 20
- Branch **B13**, GE/BR cable, to PIN 38
- Branch **B14**, BL/RT cable, to PIN 1
- Branch **B15**, BL/BR cable, to PIN 21
- Branch **B16**, GE/SW cable, to PIN 37
- Branch **B17**, GE/BR cable, to PIN 2
- Branch **B18**, BL/SW cable, to PIN 3
- Branch **B19**, BL/BR cable, to PIN 19
- Branch **B22**, BL/GE cable, to PIN 13

Connect plug **X254** to the base module (1).

11. To install the headlight retrofit wiring harness

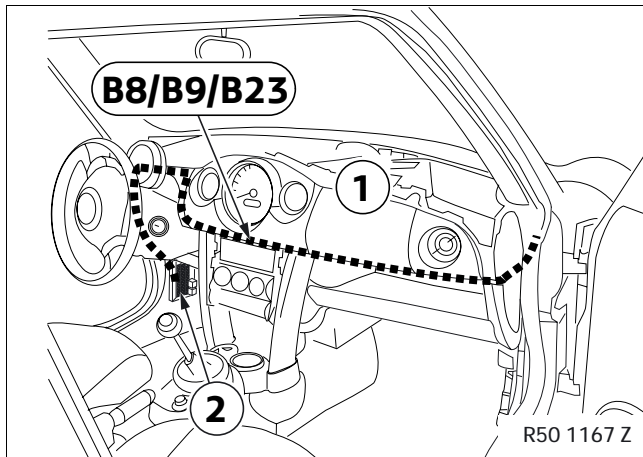

Route branches **B8**, **B9** and **B23** through the instrument holder (1) to fuse box II (2) along the standard wiring harness.

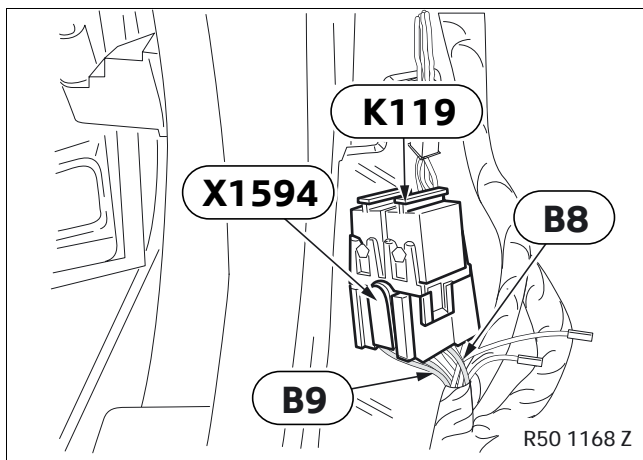

R50/R53 cars only

▶ Disconnect the old cables, insulate them and tie them back. ◀

Route branches **B8**, SW/BR cable, and **B9**, SW/BL cable, to the washing water pump relay **K119**, and connect it to relay plug **X1594** as follows:

- Branch **B8**, SW/BR cable, to PIN 6
- Branch **B9**, SW/BL cable, to PIN 1

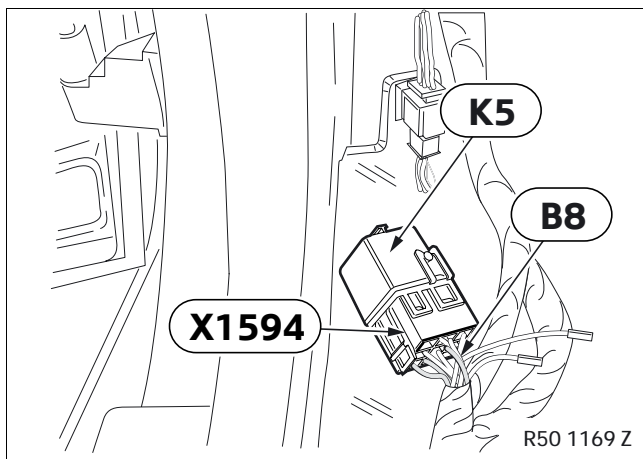

R52 cars only

▶ Disconnect the old cable, insulate it and tie it back. ◀

Route branches **B8**, SW/BR cable, and **B9**, SW/BL cable, to the washing water pump relay **K5**, and connect it to relay plug **X1594** as follows:

- Branch **B8**, SW/BR cable, to PIN 2

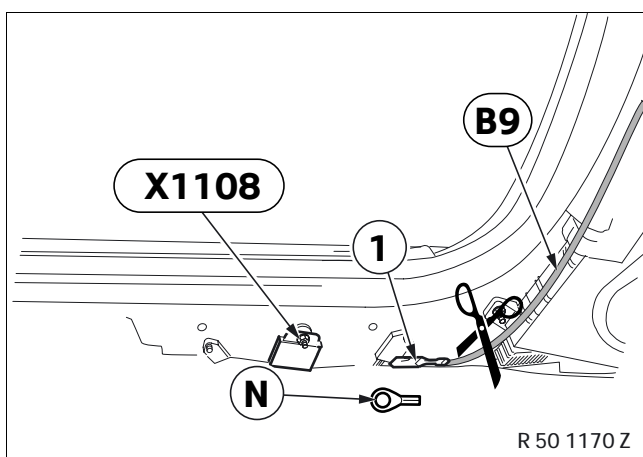

Route branch **B9**, SW/BL cable, to earth post **X1108**.

Cut socket contact (1) off branch **B9**, SW/BL cable, and crimp on eyelet **N**.

Connect branch **B9**, SW/BL cable, to earth post **X1108**.

11. To install the headlight retrofit wiring harness

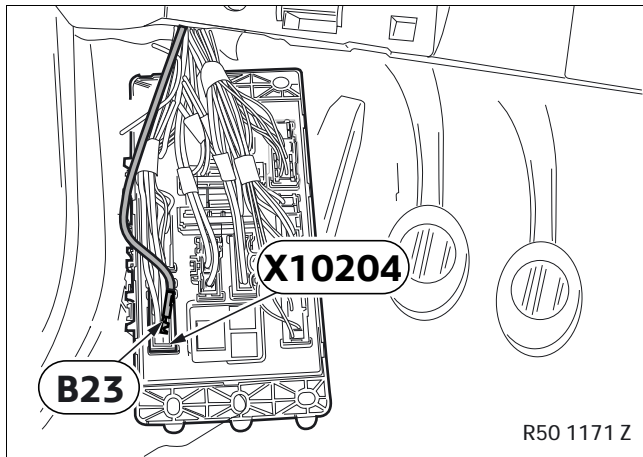

Cars built before 01/05 only

Connect branch **B23**, GN/GE cable, to the 12-pin natural-colored plug **X10204** PIN 10.

Cars built after 01/05 only

Connect branch **B23**, GN/GE cable, to the 12-pin natural-colored plug **X10204** PIN 4.

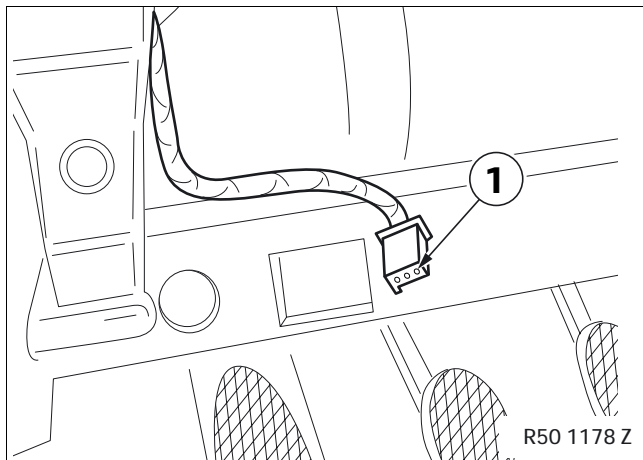

Tie back the manual headlight adjustment control plug (1).

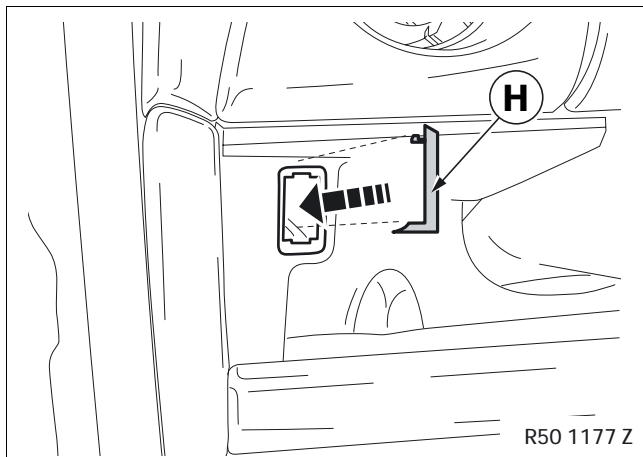

Clip the trim **H** into the oddments box.

12. Concluding work and coding

This retrofit system requires coding.

- Connect battery
- Program / encode the retrofit with SSS (software service station) via the **Retrofit** path
- Conduct a brief test
- Conduct a function test
- Re-assemble the car

13. Headlight adjustment control retrofit wiring harness circuit diagram

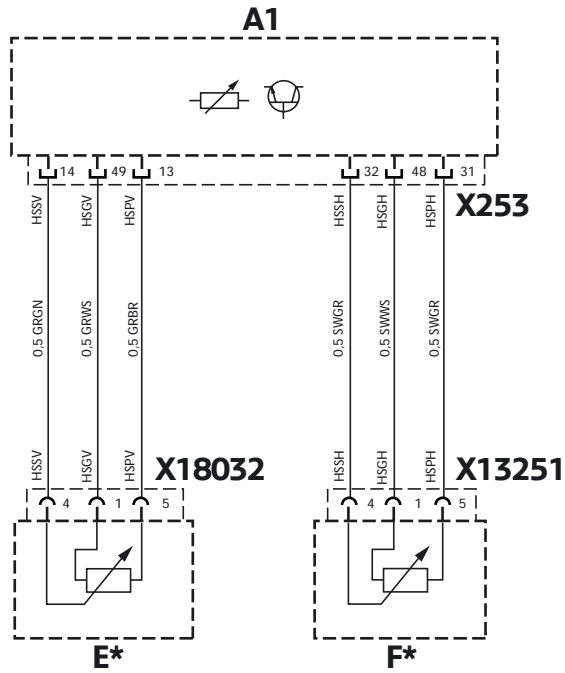

R50 1166 Z

Legend

- A1** Base module
- E*** Load sensor, front
- F*** Load sensor, rear
- X253** 54-pin SW socket casing, to the base module
- X13251** 6-pin BR socket casing, to rear load sensor
- X18032** 6-pin BR socket casing, to front load sensor

All the designations marked with an asterisk (*) apply only to these installation instructions or this circuit diagram.

Cable colors

- BR Brown
- GN Green
- GR Grey
- SW Black
- WS White

14. Headlight retrofit wiring harness circuit diagram (R50/R53 cars only)

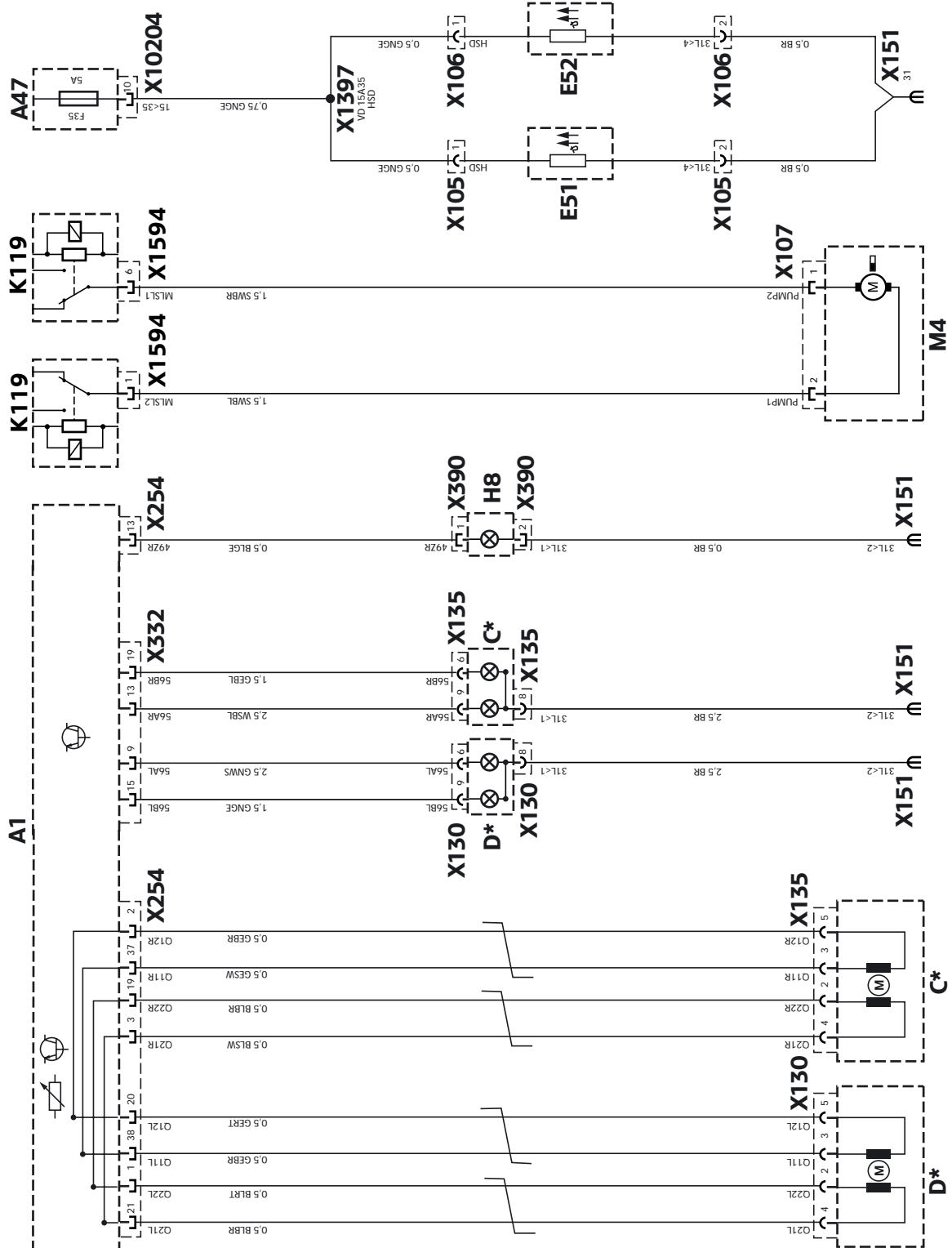

R50 1162 Z

14. Headlight retrofit wiring harness circuit diagram (R50/R53 cars only)

Legend

A1	Base module
A47	Fuse holder II, A pillar, left
C*	Xenon headlight, right
D*	Xenon headlight, left
E51	Heated spray jet, left
E52	Heated spray jet, right
H8	Additional indicator light, front right
K119	Washing pump relay
M4	Washer pump
X105	2-pin SW plug casing
X106	2-pin SW plug casing
X107	SW 2-pin socket casing
X130	SW 9-pin socket casing
X135	SW 9-pin socket casing
X151	Right door sill earth point
X254	54-pin socket casing, natural color
X332	20-pin socket casing GN
X390	SW 2-pin socket casing
X1397	Terminal 15 connector, heated spray jet
X1594	SW/WS relay socket
X10204	12-pin natural-colored socket housing, before 01/05 PIN 10, after 01/05 PIN 4

All the designations marked with an asterisk (*) apply only to these installation instructions or this circuit diagram.

Cable colors

BL	Blue
BR	Brown
GE	Yellow
GN	Green
RT	Red
SW	Black
WS	White

15. Headlight retrofit wiring harness circuit diagram (R52 cars only)

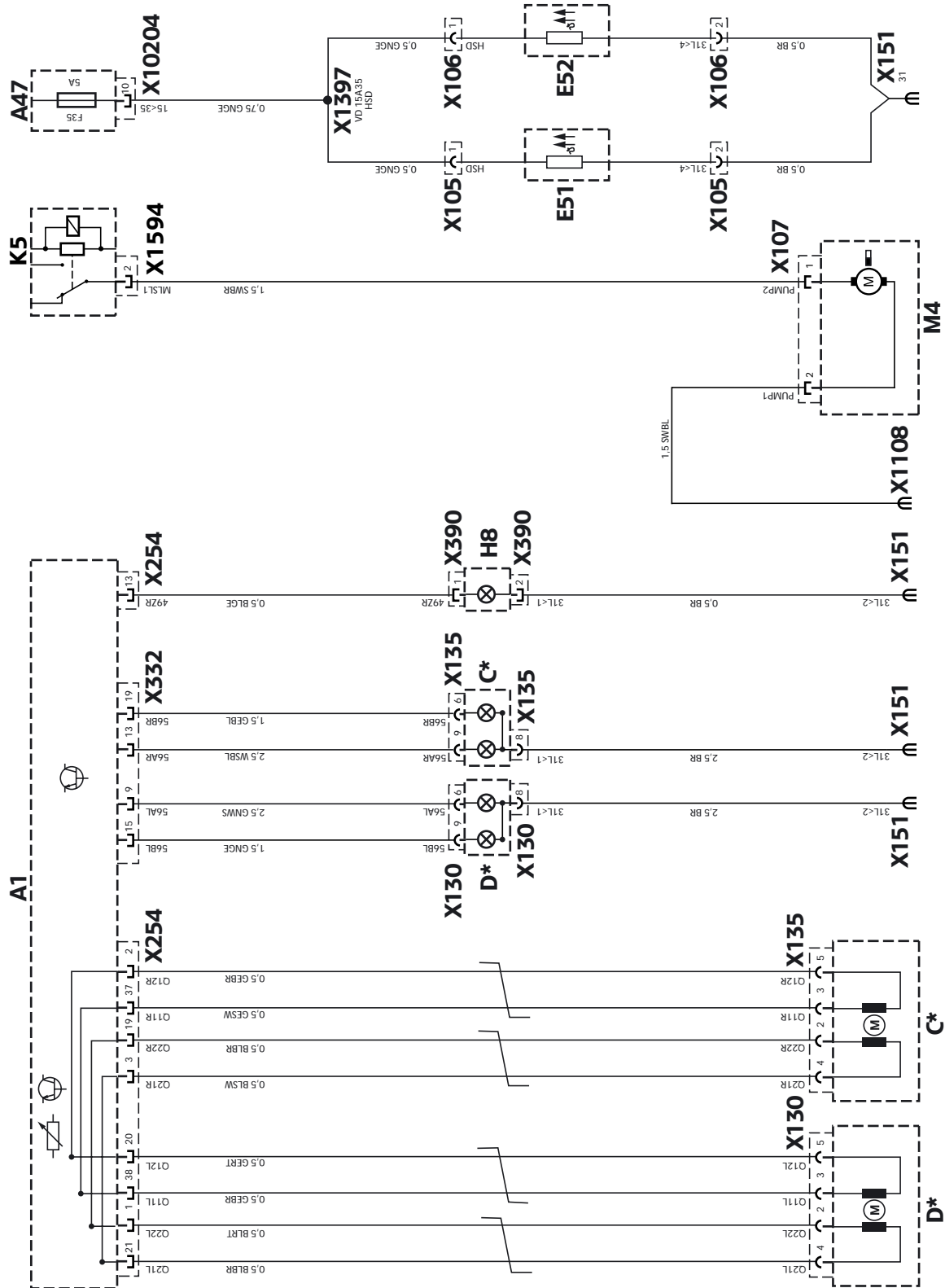

R50 1176 Z

15. Headlight retrofit wiring harness circuit diagram (R52 cars only)

Legend

A1	Base module
A47	Fuse holder II, A pillar, left
C*	Xenon headlight, right
D*	Xenon headlight, left
E51	Heated spray jet, left
E52	Heated spray jet, right
H8	Additional indicator light, front right
K5	Washing pump relay
M4	Washer pump
X105	2-pin SW plug casing
X106	2-pin SW plug casing
X107	SW 2-pin socket casing
X130	SW 9-pin socket casing
X135	SW 9-pin socket casing
X151	Right door sill earth point
X254	54-pin socket casing, natural color
X332	20-pin socket casing GN
X390	SW 2-pin socket casing
X1397	Terminal 15 connector, heated spray jet
X1594	SW/WS relay socket
X10204	12-pin natural-colored socket housing, before 01/05 PIN 10, after 01/05 PIN 4

All the designations marked with an asterisk (*) apply only to these installation instructions or this circuit diagram.

Cable colors

BL	Blue
BR	Brown
GE	Yellow
GN	Green
RT	Red
SW	Black
WS	White