

John Cooper Works Tuning. Installation Instructions.



Retrofit Tuning Kit MINI Cooper S (R56)

Retrofit kit no.: 11 12 0 434 320 John Cooper Works Tuning Kit ECE
11 12 0 434 321 John Cooper Works Tuning Kit US

Installation time

The installation time of:

- **approx. 4 hours** for ECE vehicles
- **approx. 2 hours** for SAE vehicles

may vary depending on the condition of the car and the equipment in it.

The vehicle must be updated to the latest I-level status by flashing before installing the retrofit. Different programming times are necessary depending on the age of the vehicle and the work already performed on the vehicle so that no time requirements can be specified here. The installation time does not include the time required for programming/encoding which depends on the age of the vehicle and the equipment in it.

Important information

These installation instructions are primarily designed for use within the MINI dealership organisation as well as by authorised MINI service companies.

In any event, the target group for these installation instructions is specialist personnel trained on MINI cars with the appropriate specialist knowledge.

All work must be completed using the latest MINI repair manuals, circuit diagrams, servicing manuals and work instructions, in a rational order, using the prescribed tools (special tools) and observing current health and safety regulations.

In the event of installation or functional problems, limit troubleshooting session to 0.5 hours for mechanical jobs and 1.0 hour for electrical jobs.

To avoid unnecessary extra work and costs, send a corresponding enquiry via the Aftersales Assistance Portal (ASAP) using the technical parts support application.

Please quote the following:

- vehicle identification number,
- part number of the retrofit kit,
- exact description of the problem,
- work already carried out.

Do not archive the hard copy of these installation instructions since daily updates are made by ASAP!

All pictures show LHD cars; proceed accordingly on RHD cars.

Pictograms

 Denotes instructions that draw your attention to special features.

◀ Denotes the end of the instruction or other text.

Installation Information

If the spark plugs were last changed 10,000 km ago at the time the John Cooper Works tuning kit is installed, the spark plugs should be changed in addition as part of the tuning kit installation (for part number and designation of spark plugs, refer to the electronic parts catalogue).

Important information that must be observed after installing the John Cooper Works tuning kit and to which the customer's attention should be drawn:

 The spark plugs must be replaced at each oil change after installation of the John Cooper Works tuning kit. ▶

Special tools required

00 2 270, Locating device

17 2 050, Set of pliers

00 9 322, Installation wedge

11 7 020, SW 22 socket wrench insert

00 2 210, Exhaust pipe cutter

Contents

Section	Page
1. Parts overview	4
2. Parts overview (additionally for ECE vehicles)	5
3. Preparatory work	6
4. Installing John Cooper Works Tuning Kit	7
4.1 Installing exhaust	7
4.2 Installing air filter	9
4.3 Installing emblems	11
4.4 Affixing label	12
4.5 Programming and coding the Digital Motor Electronics (DME)	13
5. Workshop certificate	14
6. Concluding work	15
7. Workshop certificate form	16

1. Parts overview

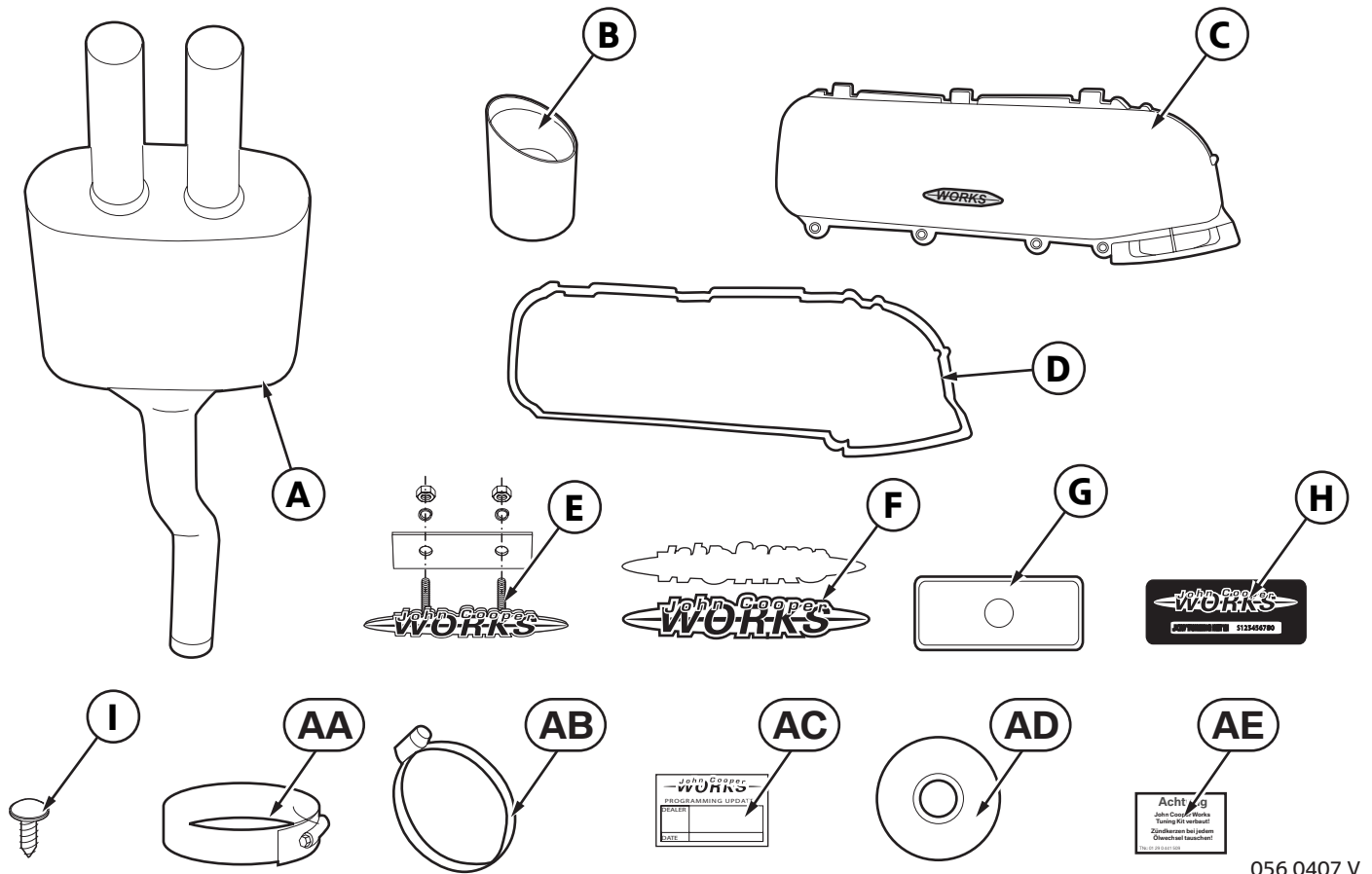

056 0407 V

Legend

- | | |
|-----------------------------------|-----------------------------------|
| A Exhaust | H Type plate |
| B Exhaust embellisher (2x) | I Stud |
| C Air filter | AA Clip |
| D Air filter seal | AB Hose clip, air filter |
| E Emblem, front | AC Control unit label |
| F Emblem, rear | AD CD with activation code |
| G Type plate holder | AE Service sticker |

2. Parts overview (additionally for ECE vehicles)

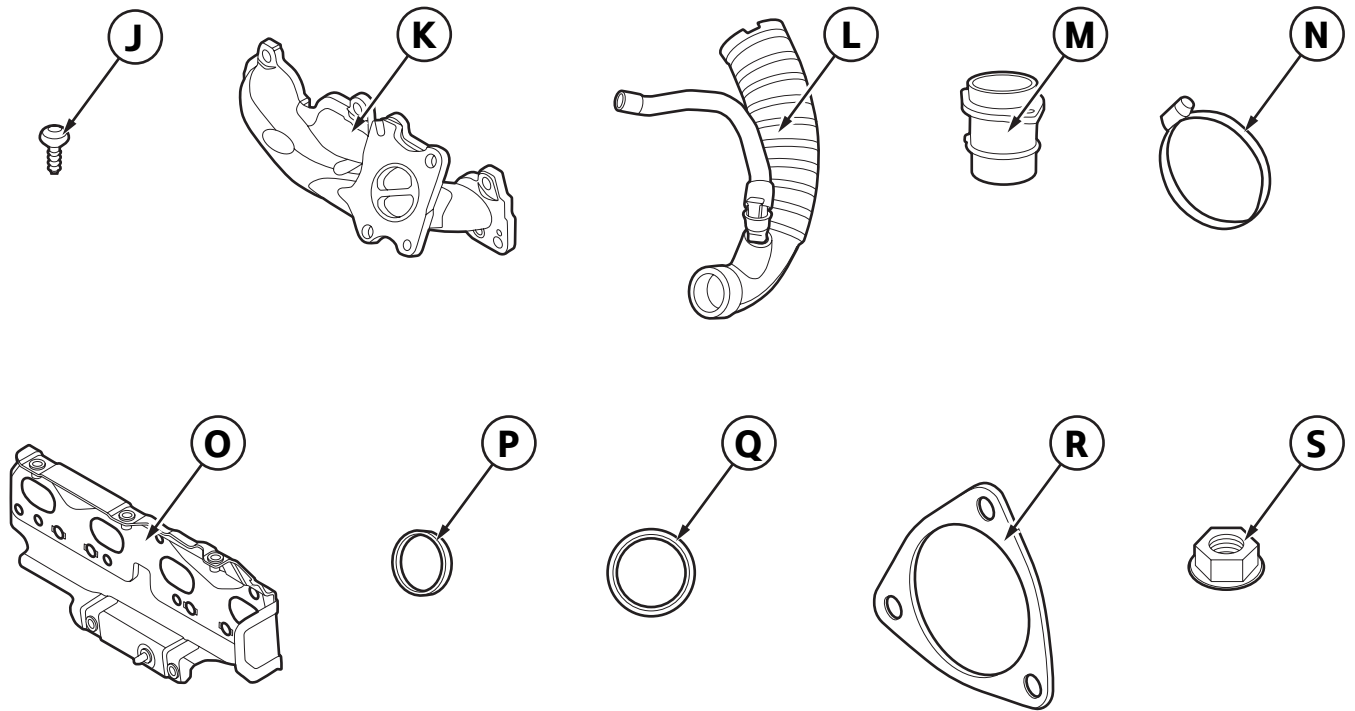

056 0319 V

Legend

J Screw, connecting piece (2x)

K Exhaust manifold

L Bellows

M Connecting piece

N Hose clip, bellows

O Heat shield

P Seal, turbocharger

Q Seal

R Gasket

S Hexagon nut (3x)

3. Preparatory work

	TIS No.
Conduct a brief test	—
Disconnect the negative terminal of the battery	12 00 ...
The following components must be removed beforehand on ECE vehicles	
Monitor sensor	11 78 545
Control sensor	11 78 510
Wheel arch trim, front	51 13 102
Bumper panel trim	51 11 164
Trim cover on front grille	51 13 003
Set front panel in assembly position	41 33 600
Exhaust catalytic converter	18 32 005
Coolant expansion tank	17 11 100
Exhaust manifold	18 40 040

4. Installing John Cooper Works Tuning Kit

4.1 Installing exhaust

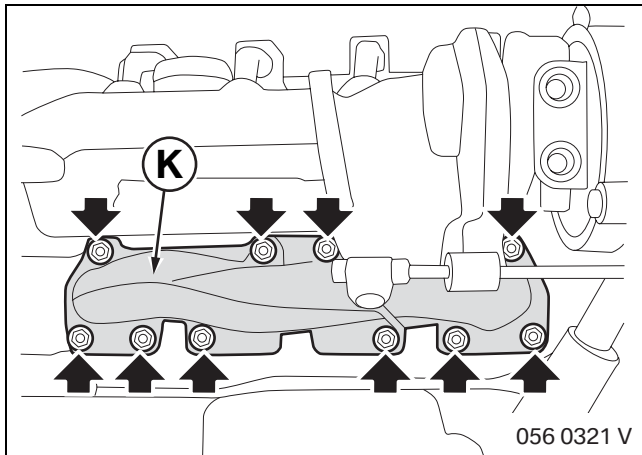

Only on ECE vehicles:

Secure turbocharger with seal **P** to exhaust manifold **K** as per TIS No. 18 40 040.

Install exhaust manifold **K** together with heat shield **O** as per TIS No. 18 40 040.

Now install existing exhaust catalytic converter with seal **R** and nuts **S** as per TIS No. 18 32 005.

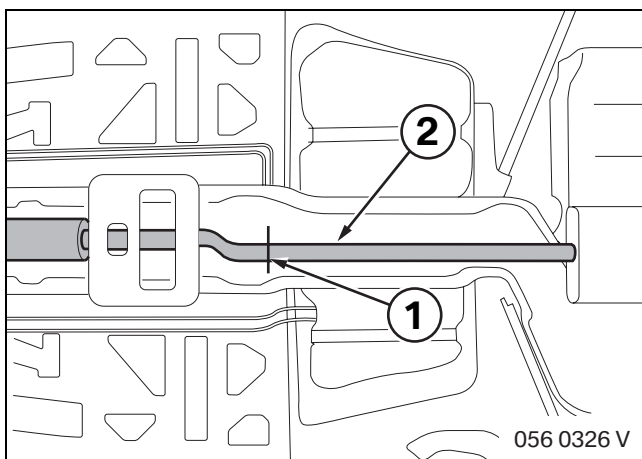

For all vehicles:

The cutting point (1) for the rear silencer is marked with a notch on the pipe.

Use special tool (00 2 210) to cut exhaust pipe (2) at the marked point and deburr.

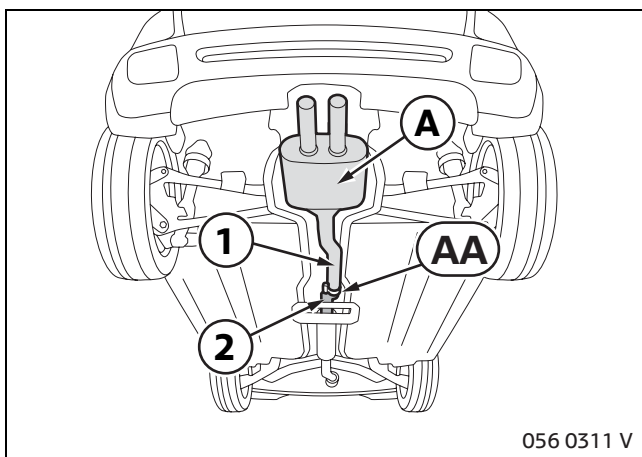

Secure pipe (1) of exhaust **A** with clip **AA** to primary silencer (2) and tighten to 55 Nm +/- 5 Nm.

Mount exhaust **A** in the rubber mounts as per TIS No. 18 12 030.

4. Installing John Cooper Works Tuning Kit

4.1 Installing exhaust

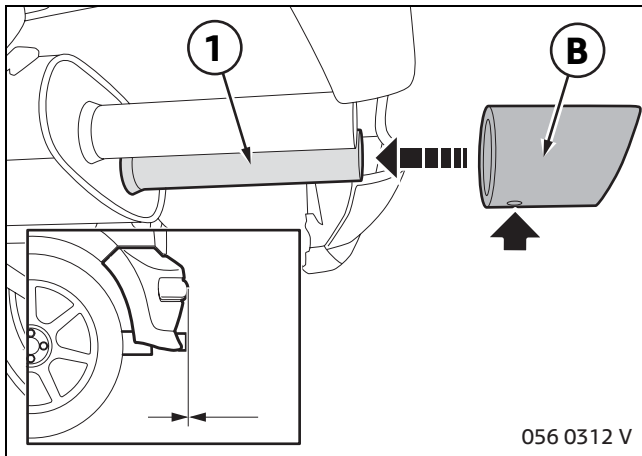

▶ Centre the exhaust embellisher **B** and align parallel.

The exhaust pipe embellisher **B** must not protrude beyond the section of body above them.

Install exhaust pipe embellisher **B** flush with the section of body above them. ◀

Fit exhaust pipe embellisher **B** onto pipe (1) of exhaust **A** and firmly tighten.

4. Installing John Cooper Works Tuning Kit

4.2 Installing air filter

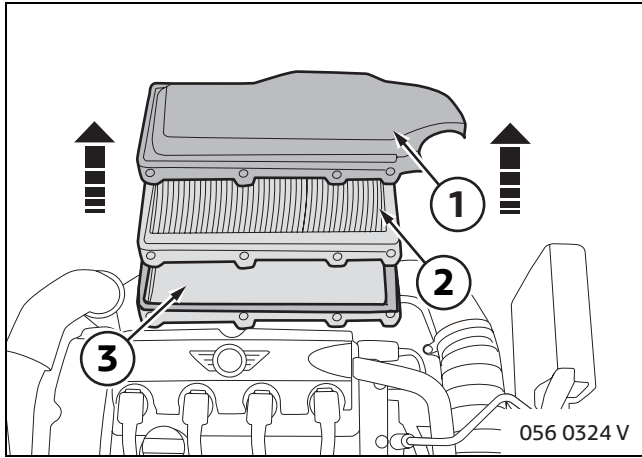

Remove the upper section of air filter housing (1) and remove filter element (2). The bottom section of the air filter housing (3) remains in the vehicle.

▣ The upper section of the air filter housing (1) and filter element (2) are no longer required. ◀

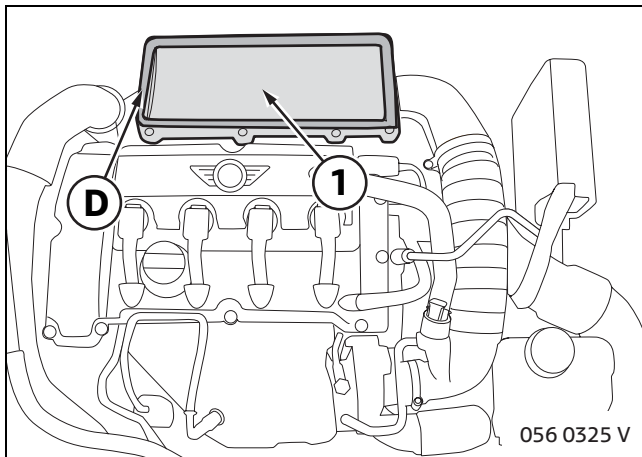

Fit seal **D** on bottom section of air filter housing (1).

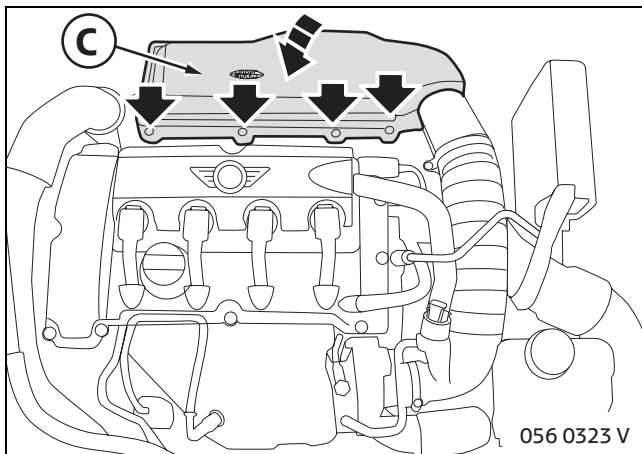

Fit air filter **C** on bottom of housing and secure as per TIS No. 13 71 000.

4. Installing John Cooper Works Tuning Kit

4.2 Installing air filter

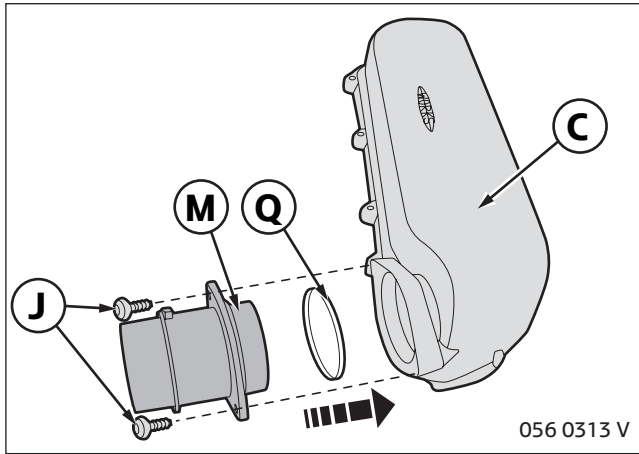

Only on ECE vehicles:

Fit seal **Q** onto connecting piece **M**.

Fit connecting piece **M** into air filter **C** and secure with screws **J**.

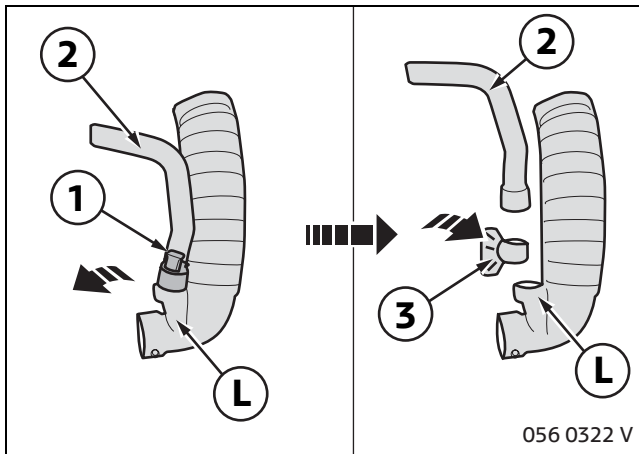

Remove the connector (1) from the connection between bellows **L** and hose (2) and replace by the connecting piece (3) originally installed in the vehicle.

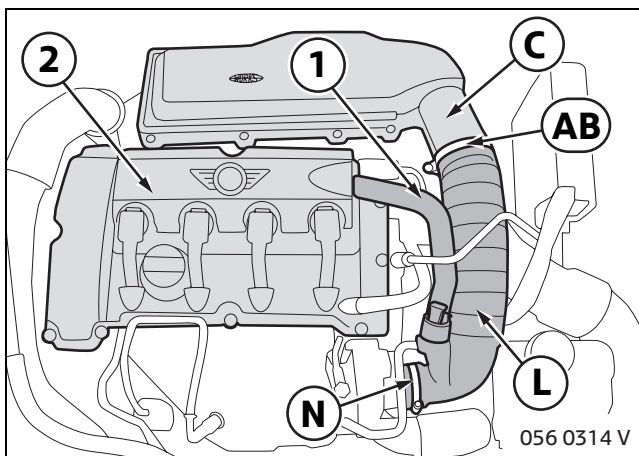

Secure bellows **L** with hose clip **N** to the intake connection piece and hose clip **AB** on air filter **C**. Connect hose (1) to cylinder head cover (2).

Only on SAE vehicles:

Secure existing bellows to air filter **C** with hose clip **AB**.

4. Installing John Cooper Works Tuning Kit

4.3 Installing emblems

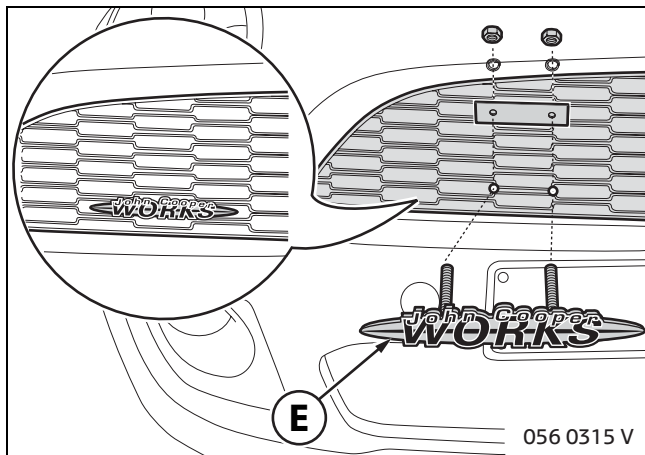

Insert front emblem **E** through the fourth column in the grille as illustrated.

Secure emblem **E** from behind with the plate, snap rings and nuts.

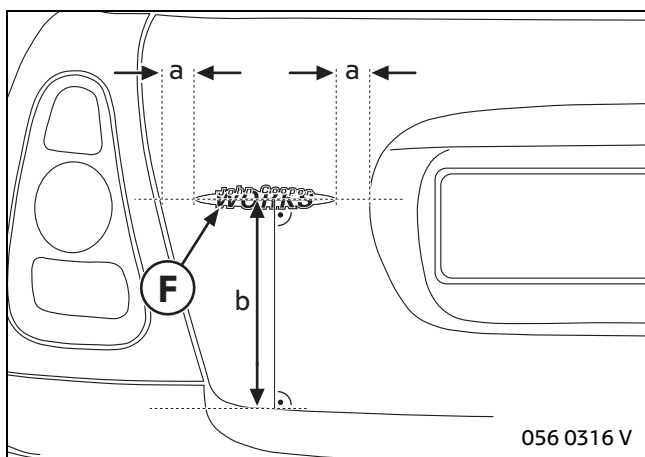

Adhere the double-sided adhesive tape to the back of rear emblem **F**. Use benzene to clean the adhesion surface.

Align rear emblem **F** in position between the edge of the rear hatch and the recess for the number plate.

If the "Cooper S" model badge is mounted, align and adhere rear emblem **F** on the same level.

$a = 35 \text{ mm}$

$b = 235 \text{ mm}$

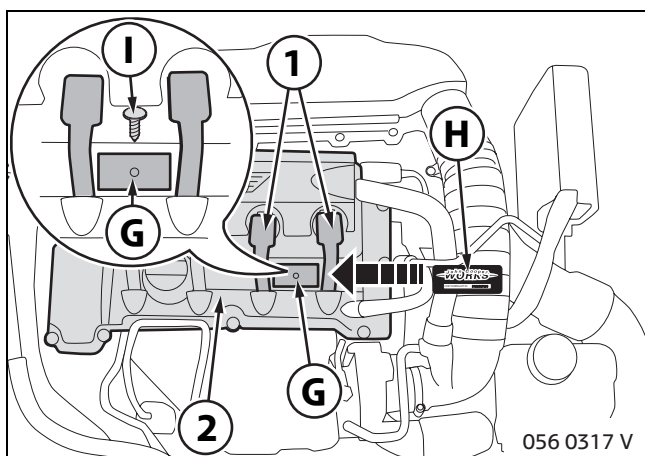

Remove the protective film from the adhesive tape on the back of type plate holder **G**. There is a hole in the cylinder head cover (2) in the middle between the ignition leads (1). Secure the type plate holder **G** in this hole with stud **I** and press down.

Peel the protective film off the adhesive tape of type plate **H** and adhere type plate **H** in holder **G**.

4. Installing John Cooper Works Tuning Kit

4.4 Affixing label

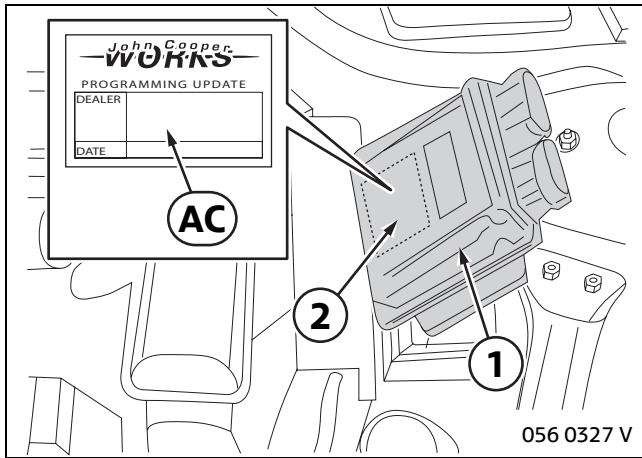

Remove the engine control unit (1) according to TIS number 12 14 550. Do not unplug the cables.

Enter the dealer's name, date and software release before affixing sticker **AC** on the engine control unit (1).

Use benzene to clean the adhesion surface (2).

Affix sticker **AC** and install engine control unit (1) as per TIS number 12 14 550.

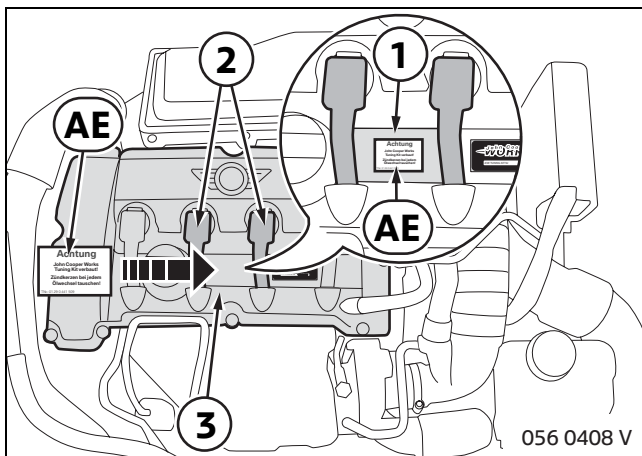

Use benzene to clean the adhesion surface (1) between the ignition cables (2) with petrol.

Affix service sticker **AE** onto the cylinder head cover (3) centrally between the ignition cables (2).

4. Installing John Cooper Works Tuning Kit

4.5 Programming and coding the Digital Motor Electronics (DME)

 A Software Service Station (SSS) is required for programming and coding the Digital Motor Electronics (DME). ◀

John Cooper Works data are provided on Progman DVDs as of Version 26.0. Make sure that the battery is connected and charged, and that a battery charger is connected in the FSV mode. Make sure a connection is established between OP(P)S and SSS. Prior to programming, carry out a short test to make sure that the DME is working correctly.

Procedure

1. Start a Progman session, select the required interface (OP(P)S) and press "Next" to confirm selection.
 2. Enter a unique name in the "Designation" box of the session and press "Next".
 3. Select the model series R56 under MINI. Messages appear indicating that the session has started and the vehicle data are being determined.
 4. Select "Load SW" and answer the question as to whether the control units have been replaced with "No".
 5. If a routine for updating the vehicle software appears, completely work through this routine first. Follow the on-screen instructions. Then repeat points 1 to 4.
 6. Select the "Modification" menu item in the navigation bar.
 7. A submenu will appear. Select "JCW Tuning Kit".
 8. Confirm the determined routine and the estimated execution time and follow the on-screen instructions. The DME will be programmed as part of the routine. If the code is requested in the instructions, insert the Tuning Kit CD supplied with activation code "**AD**" into the SSS.
 9. A final report appears on completion of the routine. Other than undeletable fault code entries, this report should contain no error messages. If errors occurred, follow the instructions in the Progman user documentation.
 10. Turn off the ignition, wait 15 seconds and switch on the ignition again.
 11. Now check whether all systems are functioning correctly.
- Reset in the same order as installation.

5. Workshop certificate

WORKS

Werkstatt-Bescheinigung

Hiermit wird bestätigt, dass an dem nachfolgend genannten Fahrzeug der John
Coope-Bike's Baureihe (11, 12, 300, 473) komplett verbaut wurde. Im einzelnen
wurden folgende Komponenten umgesetzt:

1. Steuergerät mit Softwarestand ACW
2. Kompressor 01 850 0 30 3540
3. Zylinderkopf ACW (04070)
4. Einbaueinbaueinheit CMC 0210 1814791
5. Zylinderkopf NGK 0431521P

Fahrzeugtyp:
Fahrzeugtypens.-Abz.:
Fahrzeughalter (Name u. Anschrift):

Ort, Datum:

Unterschrift der verantwortlichen Person:

Kfz-Betrieb (Druckstempel)

050 0558 V

▶ The workshop certificate (1) is an integral part of the installation instructions (see chapter 7, Form for workshop certificate). ◀

Enter the last seven digits of the vehicle identification number plus the name and address of the vehicle owner in the box marked (2).

Enter the location, date and signature of the installer, company name and stamp of the specialist workshop in the box marked (3).

▶ The workshop certificate (1) should be presented together with the certificate to the registration authority. ◀

6. Concluding work

- Conduct a brief test
- Conduct a function test
- Reassemble the vehicle



Workshop certificate

This certificate confirms that the John Cooper Works Tuning Kit (11 12 0 434 320 or 11 12 0 434 321) has been installed in full on the vehicle specified below.

The following components have been modified:

1. Rear silencer
2. Air filter housing with filter element
3. Exhaust manifold (only for ECE vehicles)

Vehicle type: MINI Cooper S (R 56)

Vehicle ident. no.: _____

Vehicle owner: Name and address: _____

Place, date

Signature of the person responsible