



Parts and Accessories Installation Instructions

John Cooper Works tuning kit MINI Cooper S (R53)

Retrofit kit part number: 11 12 0 302 673.



Installation time:

The installation time of approx. 9.0 hours can vary depending on the condition and equipment of the vehicle.

Important information:

- These Installation instructions are mainly intended for use in the MINI dealership network as well as by authorised MINI Service Centres.
The target group of these installation instructions are technical personnel trained on MINI vehicles with corresponding technical know-how.
- The BMW Group shall accept no liability for any damage caused by disregard of the specified working steps and information provided. In addition inappropriate installation and handling deviating from the installation instructions shall invalidate warranty claims made against the BMW Group.
- All work is to be carried out with the aid of currently valid repair instructions, maintenance manuals and working instructions in rational order with the specified tools (special tools) while paying particular attention to valid safety regulations.
- Particular care must be taken when fitting cables/wiring to ensure that they are not bent, kinked or damaged.
- All illustrations show LHD vehicles, the same procedure is to be followed analogously on RHD vehicles.
- Item numbers refer only to the overview and texts next to the respective graphic.
- Subject to technical modifications.

Important information that must be observed after installing the John Cooper Works tuning kit and to which the customer's attention should be drawn:

-  It is recommended to use only 98 RON (octane) fuel or fuel with the highest available octane number. (95 RON fuel 91 AKI minimum) ◀
-  The service and maintenance intervals are the same as for the standard Cooper S (R53). ◀
-  **NGK BKR 7 EQUIP spark plugs** are used and should be fitted at each subsequent service and maintenance interval. ◀

**Running-in:**

Please pay attention to the following information in order to achieve the optimum service life and efficiency of your vehicle.

Engine:**For the first 2000 km:**

Drive at various engine speeds and road speeds. Do not exceed an engine speed of 4500 rpm and a road speed of 150 km/h.

After 2000 km:

Engine speed and road speed can be increased gradually.

Also observe the running-in instructions if it was necessary to replace the engine. ◀



- For explanations of pictographs see EBA-CD or ASAP (Aftersales Assistance Portal).
- Do not archive the printout of these installation instructions as daily updates are conducted through ASAP!







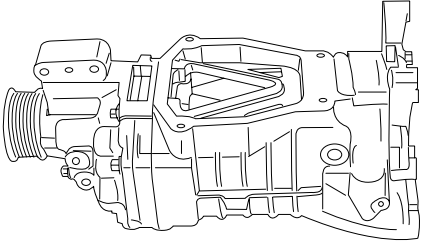
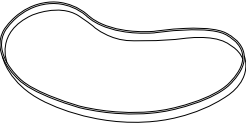

Required special tools:

See TIS No. 11 65 535,
11 12 599.

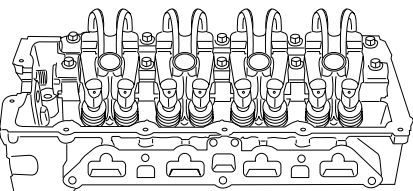
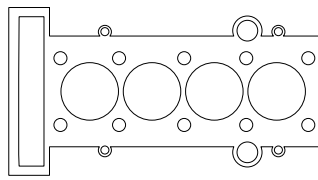
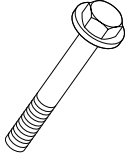
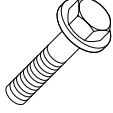
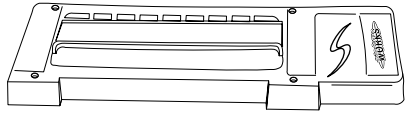
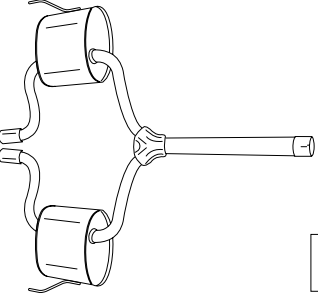
Contents

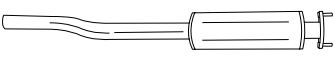
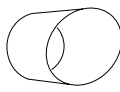
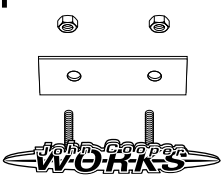
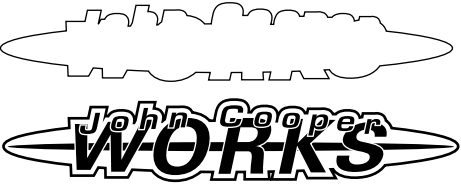
Section	Page
Important Information	1
1. Parts Overview	4
2. Preparation	5
3. Installing John Cooper Works tuning kit	6
4. Attaching John Cooper Works emblems, stickers and intercooler cover	10
5. John Cooper Works "Certificate of Authenticity"	12
6. Concluding operations	13

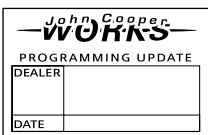
1. Parts Overview

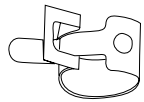
<p>A</p>  <p>1x</p>	<p>B</p>  <p>1x</p>	<p>C</p>  <p>NGK BKR 7 EQUIP</p> <p>4x</p>	
<p>D</p>  <p>1x</p>	<p>E</p>  <p>1x</p>		
<p>F</p>  <p>M10 x 150 mm</p> <p>10x</p>	<p>G</p>  <p>M8 x 45 mm</p> <p>2x</p>	<p>H</p>  <p>1x</p>	
<p>I</p>  <p>1x</p>	<p>J</p>  <p>1x</p>	<p>K</p>  <p>1x</p>	<p>L</p>  <p>2x</p>
<p>M</p>  <p>1x</p>	<p>N</p>  <p>1x</p>	<p>O</p>  <p>1x</p>	
<p>P</p>  <p>1x</p>	<p>Q</p>  <p>1x</p>	<p>R</p>  <p>2x</p>	
<p>S</p>  <p>1x</p>	<p>053 0290 B</p>		

2. Preparation

	TIS No.
Read out fault code memories	---
Disconnect battery	12 00 ...

3. Installing John Cooper Works tuning kit

3.1 Installing cylinder head and supercharger of John Cooper Works tuning kit

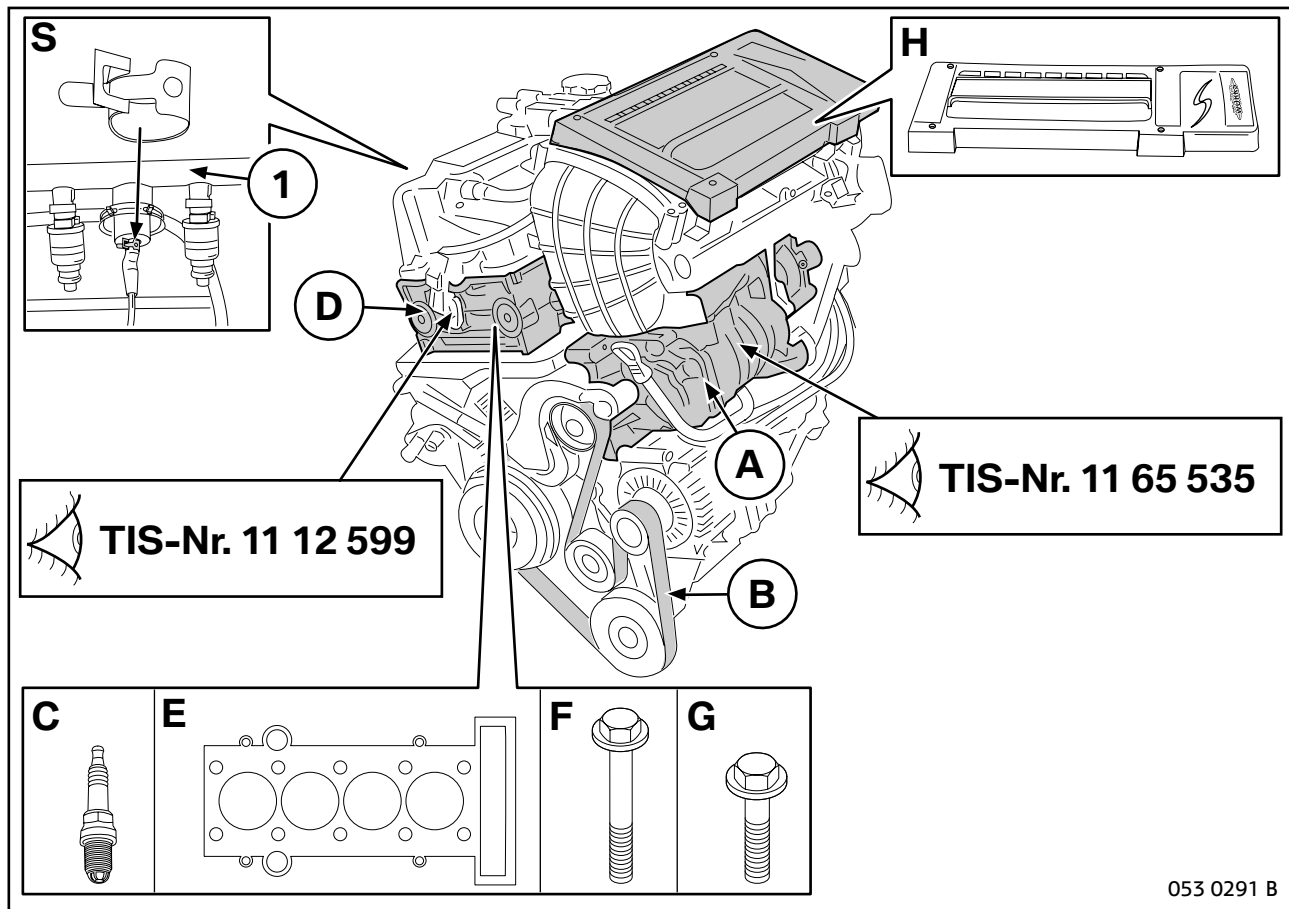

- ▶ Particular care must be taken when installing the cylinder head to ensure that the **NGK BKR 7 EQUIP spark plugs C** included in the John Cooper Works tuning kit are fitted. These spark plugs must be used at all subsequent service and maintenance intervals. ◀
- ▶ Particular care must also be taken when installing the supercharger **A** to ensure that the new ribbed V-belt **B**, included in the kit, is installed. ◀
- ▶ When installing the cylinder head the supplied parts: spark plugs **C**, set of seals/gaskets **E**, cylinder head bolts **F**, cylinder head bolts **G**, intercooler cover **H** and retaining clip **S** must be fitted in the specified steps **3.1**. ◀
- ▶ Use the four Torx screws provided to secure the John Cooper Works intercooler cover **H**. ◀
- ▶ Use retaining clip **S** to secure the vacuum hose to the fuel injection pipe **1**. ◀

3. Installing John Cooper Works tuning kit

3.2 Installing John Cooper Works exhaust system

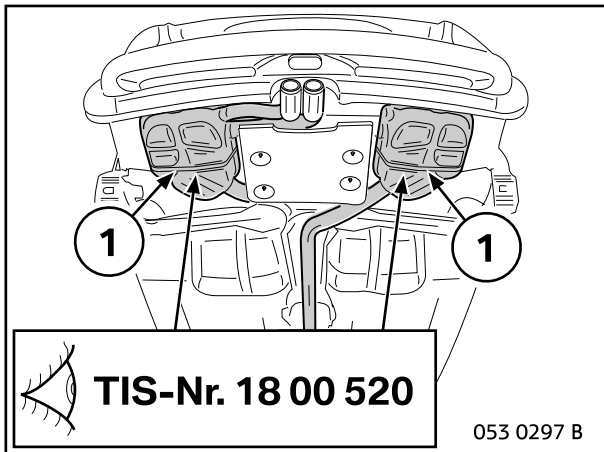

Completely remove the standard exhaust system

TIS No. 18 00 520

Also completely remove the top and bottom exhaust pipe clamps **1**.

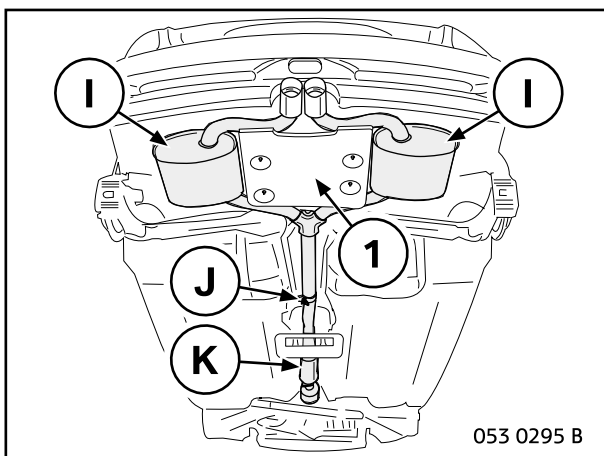

Install the John Cooper Works exhaust system **I, J, K** accordingly. The welded brackets on the John Cooper Works rear silencer **I** should be secured to the standard mounting fixtures.

▶ After installing the John Cooper Works exhaust system check whether the heat shield **1** snags against the rear silencer **I**. If necessary, rework heat shield **1** so that no vibration noise can occur. ◀

▶ Check exhaust clamp **J** for leaks. ◀

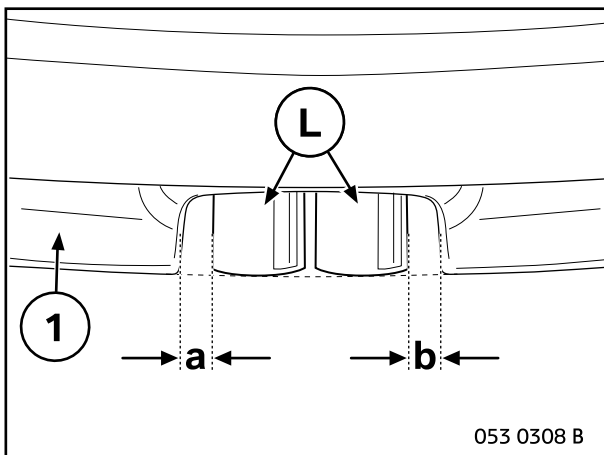

Fit the John Cooper Works exhaust covers **L** such that they end aligned flush with the rear apron **1**.

Size **a = b**

3. Installing John Cooper Works tuning kit

3.3 Programming and encoding engine control unit ECU (DME or EMS2K)



A DISplus or GT1 is necessary to program the engine control unit (DME). The John Cooper Works data is provided on the CDs as from the 1st update CD32. Make sure that a battery charger is connected and there is a hard-wired connection between the wireless head and tester.

Prior to programming, carry out a quick test and make sure there are no defects in the DME. ◀

1. As the tester is already connected, you can directly select "Encoding/Programming".
2. Select option "5. DME Programming" in the "Encoding/Programming" menu.
3. Select "3. DME Programming".
4. Select "2. Replace Control Unit".
5. Select "1. Determine Control Unit".
6. The question as to whether the original DME is still installed in the vehicle now appears. Answer this question with "NO".
7. Enter the "control unit number" of the DME (e.g. 7520019) via the user-prompted interface of the tester.
8. Enter the complete vehicle identification number (17 characters from the DME identification page).
9. Enter the assembly number (programmed control module number) for the John Cooper Works tuning kit (**Europe/Japan: 7 528 434; North America: 7 528 436**).
10. Ignore the list of alternative numbers. The definition stage is now completed and all necessary data have been saved in the tester. Now press the arrow keys to exit this section.
11. Select "2. Program Basic Control Unit".
12. Enter the last 7 characters (2 letters, 5 digits) of the vehicle identification number in order to identify the correct data.
13. The message indicating that programming may take 4 – 12 minutes now appears. Press arrow keys to continue.
14. Enter the current kilometre reading of the car.
15. Start the automatic programming procedure.
16. After programming, the tester will automatically set the DME to the electronic vehicle immobilizer (EWS).



If the system informs you at this point that the EWS control unit requires encoding, proceed as described in the following.

- A. Turn terminal 15 to OFF and disconnect the battery for 3 minutes.
- B. Reconnect the battery and turn terminal 15 to ON. ◀

17. Select ZCS/FA encoding.
18. Select "New Coding" followed by "Motronic" and carry out renewed encoding of the Motronic (DME). In this way, the systems (e.g. air conditioning) installed in the vehicle are identified so that they can be controlled via the DME.
19. After the prompt to do so, turn off the ignition and wait until the specified time interval has elapsed. Restart the car.
20. Now perform a quick test and clear the fault codes logged as the result of the programming procedure.
21. Affix a new label on the DME to identify the John Cooper Works update.
22. Finally check whether all systems such as the air conditioning for instance and the cruise control (Tempomat) if fitted are fully operational.

3. Installing John Cooper Works tuning kit

3.4 Affixing sticker on engine control unit ECU (DME or EMS2K)

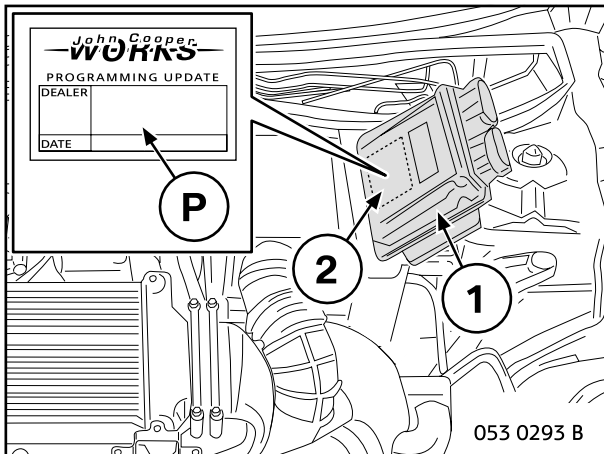

Enter the dealer, date and software status before affixing the sticker **P** to the engine control unit **1**.

Use benzine to clean the adhesion surface **2**. Attach sticker **P** and reinstall engine control unit **1**.

4. Attaching John Cooper Works emblems, stickers and intercooler cover

4.1 Attaching John Cooper Works emblem on standard front apron

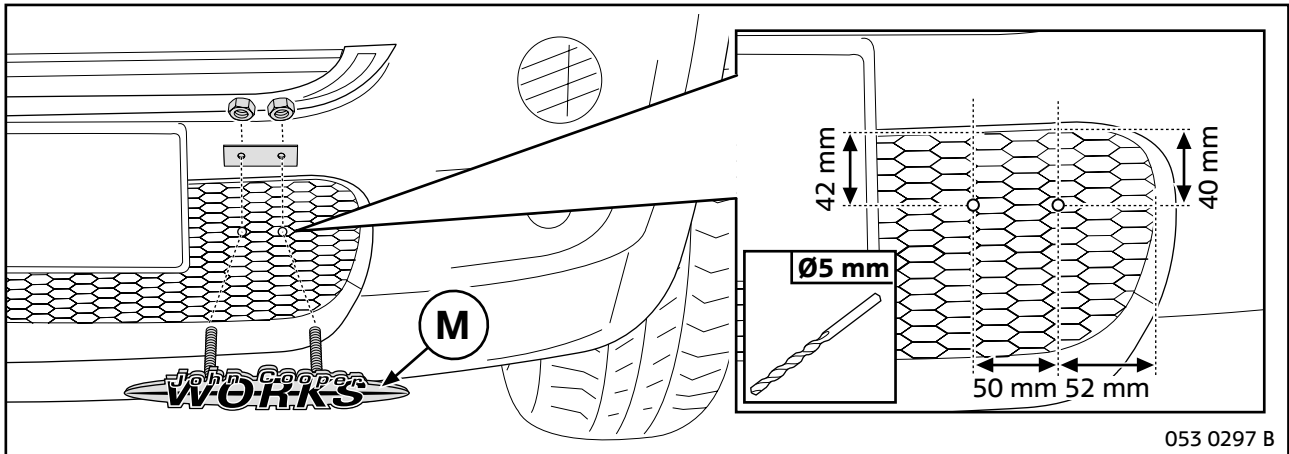

4.2 Attaching John Cooper Works emblem on accessory front apron (aerodynamics package)

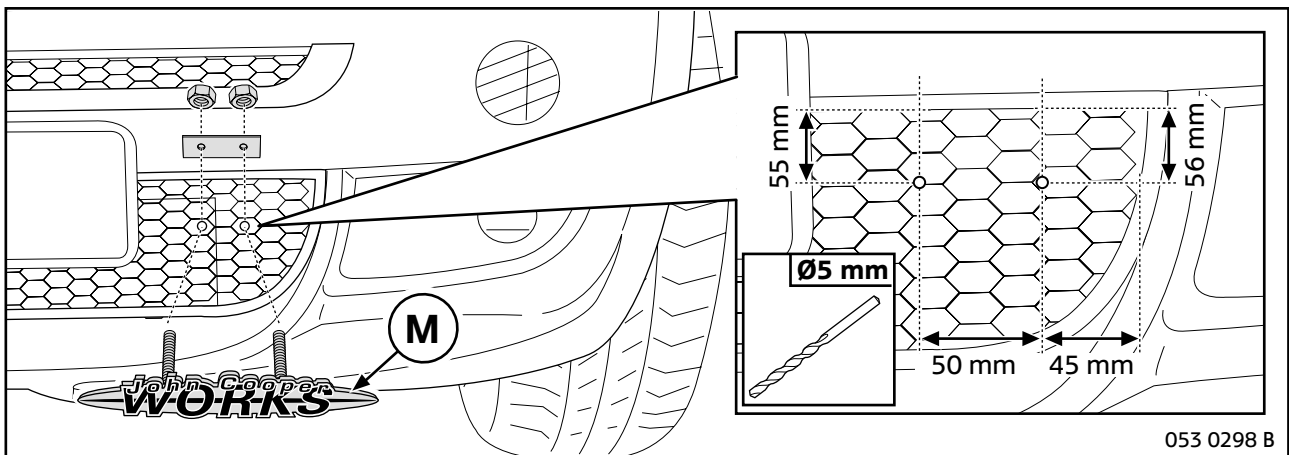

4. Attaching John Cooper Works emblems, stickers and intercooler cover

4.3 Attaching John Cooper Works emblem on valve cover

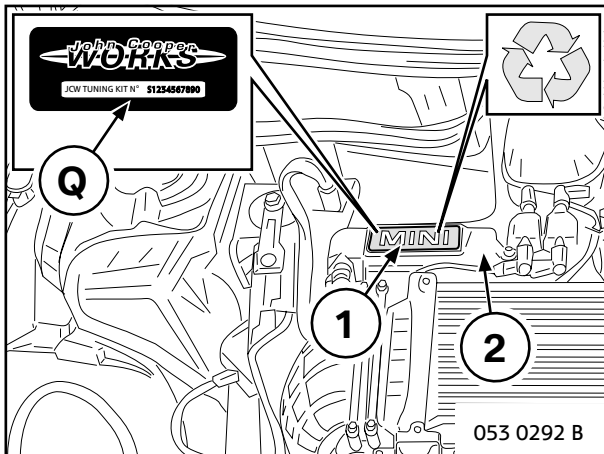

Remove original MINI emblem **1** from valve cover **2** and then clean adhesion surface with benzine.
Attach John Cooper Works emblem **Q** to valve cover.

4.4 Affixing John Cooper Works sticker on fuel filler cap

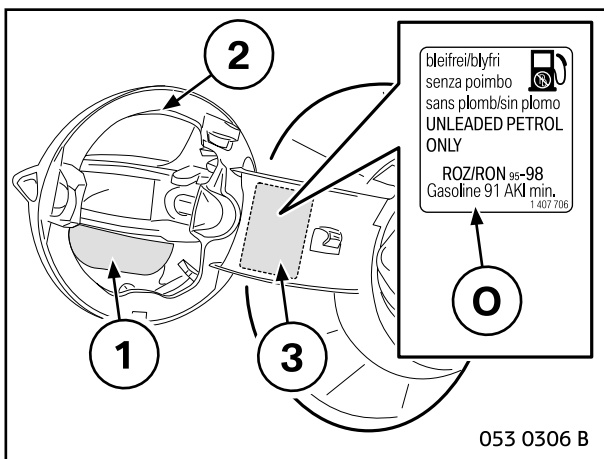

Remove original sticker **1** from the fuel filler cap **2**. Use benzine to clean the adhesion surface **3**.
Affix sticker **O** to the marked surface **3**.

4.5 Attaching John Cooper Works emblem on hatch

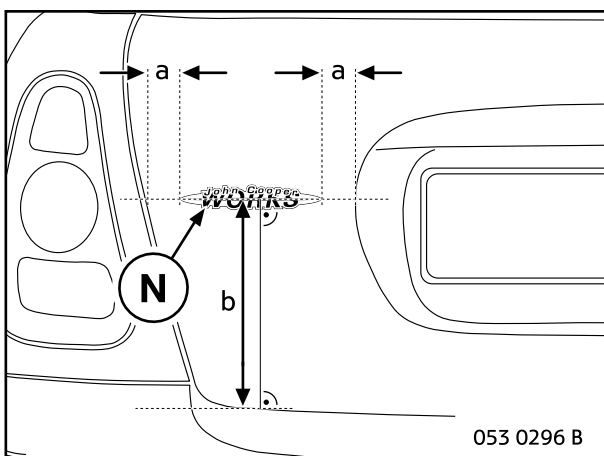

Adhere the double-sided adhesive tape to the back of the John Cooper Works emblem **N**. Use benzine to clean the adhesion surface. Determine the position of the John Cooper Works emblem between the hatch and licence plate mounting.
If the "Cooper S" model nameplate is affixed on the hatch, determine the height of the John Cooper Works emblem in relation to this nameplate.

a = 50 mm
b = 210 mm

5. John Cooper Works "Certificate of Authenticity"

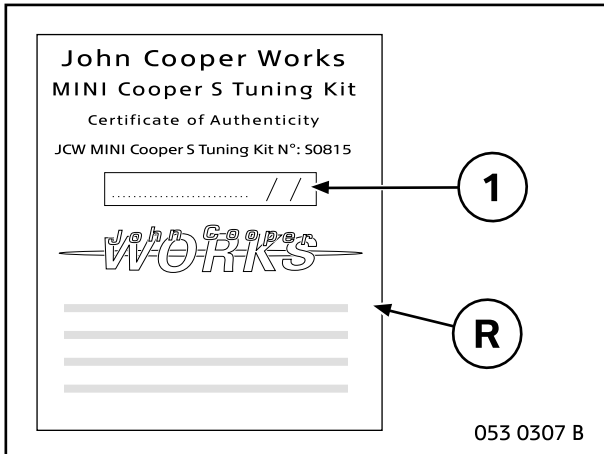

The BMW Group must be notified of the conversion with the John Cooper Works tuning kit. Disregard of this requirement shall invalidate warranty claims against the BMW Group. ◀

The last seven characters of the vehicle identification number, kilometre reading and date are to be entered in the area marked with **1**. One of the two certificates **R** should then be sent to the BMW Group. For further details please contact the parts manager of your national BMW subsidiary.



The other certificate **R** should be handed over to the customer. ◀

6. Concluding operations

Reconnect all connectors and plug connections.
Reassemble vehicle in reverse order of removal.