



Installation Instructions

Page 1 of 4

October 2007

Accessories, Grill Badge Mounting Kit

Ver 3.0

Accessory
Development

SUBJECT

GRILL BADGE MOUNTING KIT – P/N 51 13 0 443 374*
P/N 51 13 0 441 503**

* For (R56) MINI Cooper S and MINI Cooper with Aero Kit only.

**For (R56) MINI Cooper only.

MODEL

MINI Cooper (R56):	All Vehicle Production
MINI Cooper S (R56):	All Vehicle Production
MINI Cooper with Aero Kit (R56):	All Vehicle Production

SUGGESTED INSTALLATION TIME: 0.5 HOURS

Total installation time may vary depending on vehicle options and equipment.

The instructions below are developed for R56 MINI vehicles and are not to be compared to any other existing instructions for vehicles other than R56 MINI. No methods other than those specified in this document are to be used for installation in R56 MINI vehicles. Left and right are determined from the driver's seat.

Carefully read all instructions and supplements before proceeding with the installation. Reference should be made to TIS for instructions dealing with a stock part of the vehicle but not stated in detail in these instructions.

The instructions were complete and up to date at time of publication; however, changes to the vehicle or installation may have occurred. Please report any problems or changes noted with the installation to BMW Technical Hotline, along with VIN, date of manufacture and as much detail as possible.

WARNING: NO MORE THAN TWO GRILL BADGES SHOULD BE MOUNTED ONTO THE GRILL TO ENSURE SUFFICIENT AIRFLOW TO THE ENGINE.

★ ★ DO IT RIGHT THE FIRST TIME, ON TIME, EVERY TIME ★ ★

PARTS INFORMATION**Contents of Kit - P/N 51 13 0 443 374**

Description	Qty	MINI Part Number
Grill badge base plate with studs	1	N/A
Flat mounting bracket	1	N/A
M4 flat washer	2	N/A
M4 lock nut	2	N/A
Installation Instructions	1	01 29 0 441 530

Contents of Kit - P/N 51 13 0 441 503

Description	Qty	MINI Part Number
Grill badge base plate with studs	1	N/A
Grill badge base plate with angle bracket and studs	1	N/A
Flat mounting bracket	1	N/A
M4 flat washer	2	N/A
M4 lock nut	2	N/A
Installation Instructions	1	01 29 0 441 530

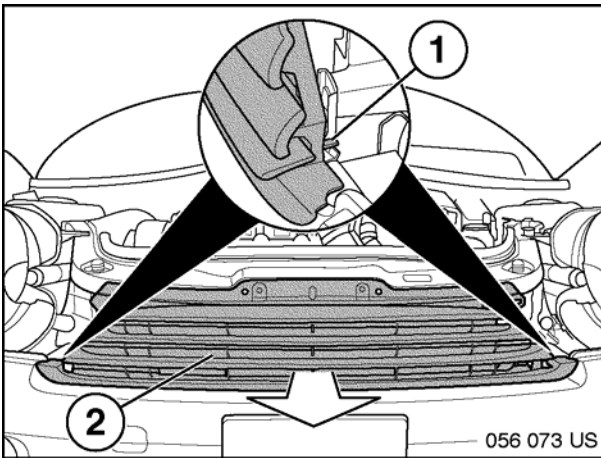
PROCEDURE:

1. Open engine compartment hood. Locate and press down on the two catches (1) to remove the lower trim on the front grill.

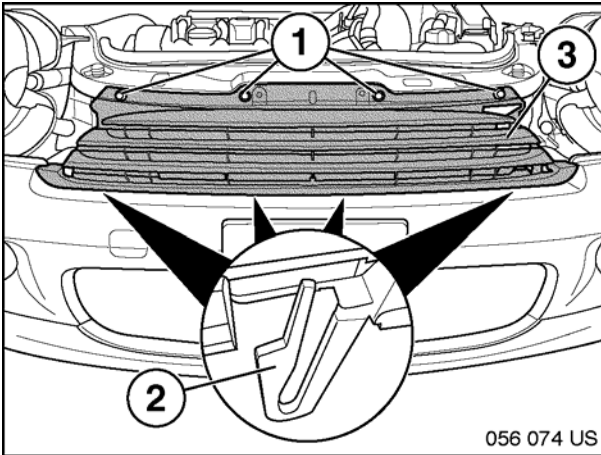

2. Remove the four expansion rivets (1) located at the top edge of the grill (3). Press together each of the four catches (2) located at the bottom edge of the grill (3) to release it. Remove grill (3) by sliding it forward.

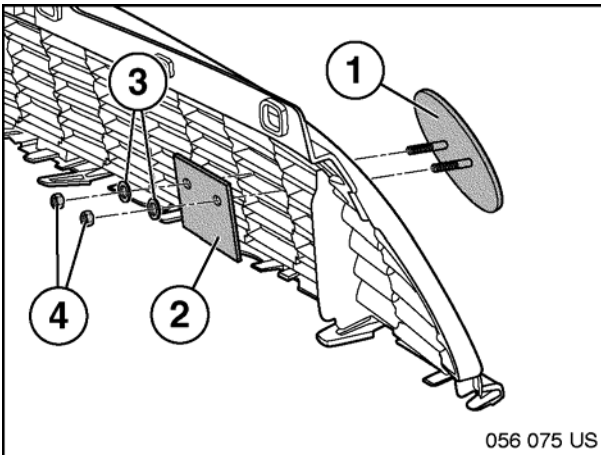

3. For R56 MINI Cooper with Aero Kit and MINI Cooper S vehicles equipped with the honeycomb grill, position the grill badge base plate (1) approximately as shown so the base plate is centered vertically on the grill.

Note: Grill badge base plate should be positioned far enough away from the side edge of the grill so it does not interfere with accessory driving lights if vehicle is so equipped.

Align the two holes in the flat mounting bracket (2) with the two studs on the back of the grill badge base plate (1) and fasten assembly to grill using flat washers (3) and 4mm locking nuts (4) included in kit.

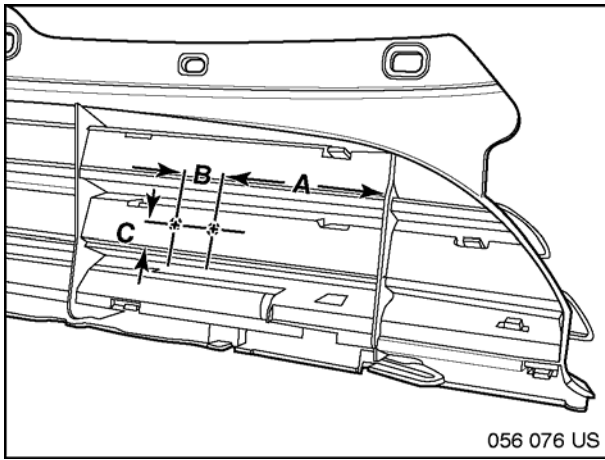

4

4. For R56 MINI Cooper with the standard chrome bar grill, drill two 4.5 mm holes. Locate mounting holes so that the first mounting hole is 4 inches (dimension "A") from the right most vertical grill support and the second mounting hole is one inch (dimension 'B') past the first mounting hole, measured on center. Both mounting holes should be located ½ inch above the bottom edge of the second grill bar base as shown.

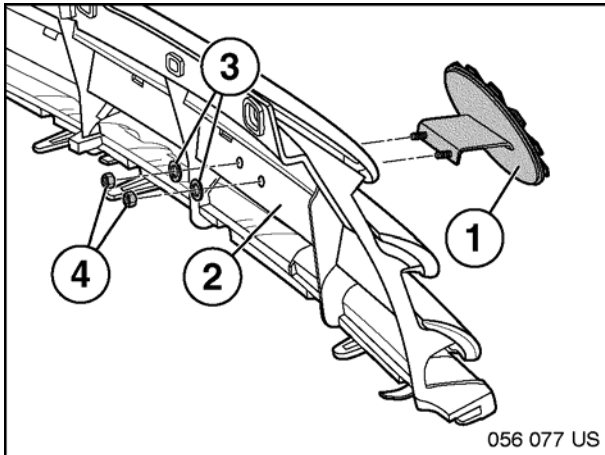

5. Align and insert the two threaded studs on the grill badge base plate into the two drilled holes. Fasten assembly to the grill using flat washers (3) and 4 mm locking nuts (4) included in kit.

Installation Complete