

John Cooper Works Tuning. Installation Instructions.



Retrofit kit - John Cooper Works Sport seat, MINI Cooper (R56)

Retrofit kit No.	52 10 0 421 081	John Cooper Works Sport seat, full leather, front left
	52 10 0 420 668	John Cooper Works Sport seat, full leather, front right
	52 10 0 420 669	John Cooper Works Sport seat, leather/Alcantara, front left
	52 10 0 420 670	John Cooper Works Sport seat, leather/Alcantara, front right

Installation time

The installation time is approx. 0.75 hours, but may vary depending on the condition of the car and the equipment in it.

The vehicle must be updated to the latest I-level status by flashing before installing the retrofit. Different programming times are necessary depending on the production age of the vehicle and the work already performed on the vehicle so that no time requirements can be specified here.

The installation time does not include the time required for programming/encoding which depends on the vehicle's age and equipment.

Important information

These installation instructions are primarily designed for use within the MINI dealership organisation and by authorised MINI service companies.

In any event, the target group for these installation instructions is specialist personnel trained on MINI cars with the appropriate specialist knowledge.

All work must be completed using the latest MINI repair manuals, circuit diagrams, servicing manuals and work instructions, in a rational order, using the prescribed tools (special tools) and observing current health and safety regulations.

To avoid unnecessary extra work and/or costs, if any installation or function problem occurs, after a brief troubleshooting session (approx. 0.5 hours), please contact the following:



- 1. Either your national subsidiary or your regional office, or**
- 2. The Support team via the Aftersales Assistance Portal (ASAP), using the optional technical parts support application.**

Specify the chassis number and the part number of the installed retrofit kit and give a precise description of the problem.



Do not archive the hard copy of these installation instructions since daily updates are made by ASAP!

All pictures show LHD cars; proceed accordingly on RHD cars.

Pictograms:

-  Denotes instructions that draw your attention to dangers.
-  Denotes instructions that draw your attention to special features.
- ◀ Denotes the end of the instruction or other text.

Installation information

-  The John Cooper Works Sport seat can be installed with individual height and inclination setting according to customer requirements. Consult the customer before installing.
For recommended seat position see Section "Seat position" on Page 8. ◀
-  The seat runner must be removed together with the bars for seat forward/backward adjustment. ◀

Following installation, the retrofit must be programmed/encoded with the software service station (SSS) via the path - **Retrofit** -.



Ensure that the cables/lines are not kinked or damaged as you install them in the car.
Costs incurred as a result of this will not be reimbursed by BMW AG.

Additional cables/lines that you install must be secured with cable ties.

Ordering information

-  The socket head cap screws for adjusting the height and angle of the John Cooper Works Sport seat are micro-encapsulated. They are used only once. ◀
Order these screws separately if necessary.
Socket head cap screws M8 x 16 (4x), part number: 52 10 0 428 234

Instructions for the customer

-  Print out the customer information at the end of the installation instructions and hand it over to the customer. ◀
-  Retrofitting the John Cooper Works Sport seat will deactivate the seat belt reminder for the front passenger seat. The driver is advised to remind the front passenger to fasten his/her seat belt.
Deactivation of the seat belt reminder has no influence on operation of the front passenger airbag. ◀
-  The vehicle's operating permit is not invalidated by retrofitting the John Cooper Works Sport seat.
The John Cooper Works Sport seat is a constituent part of the European operating permit of the MINI R56.
Acceptance of the retrofit by a technical inspection organisation as well as corresponding entry in the vehicle papers is not necessary. ◀

Contents

Section	Page
1. Parts Overview	4
2. Preparatory work	5
3. Installing John Cooper Works Sport Seat.....	6
4. Concluding work and coding	7
5. Customer information	8

1. Parts Overview

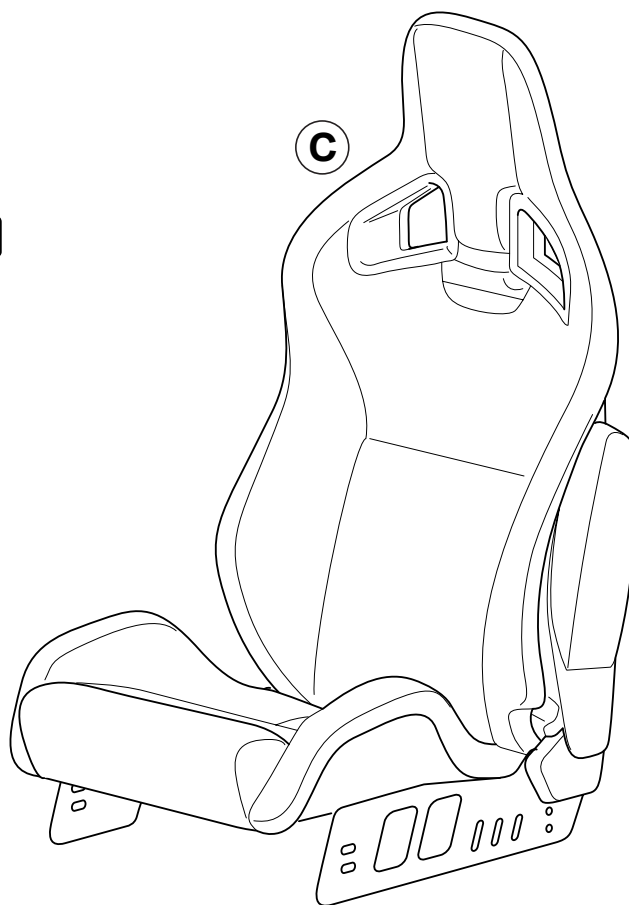
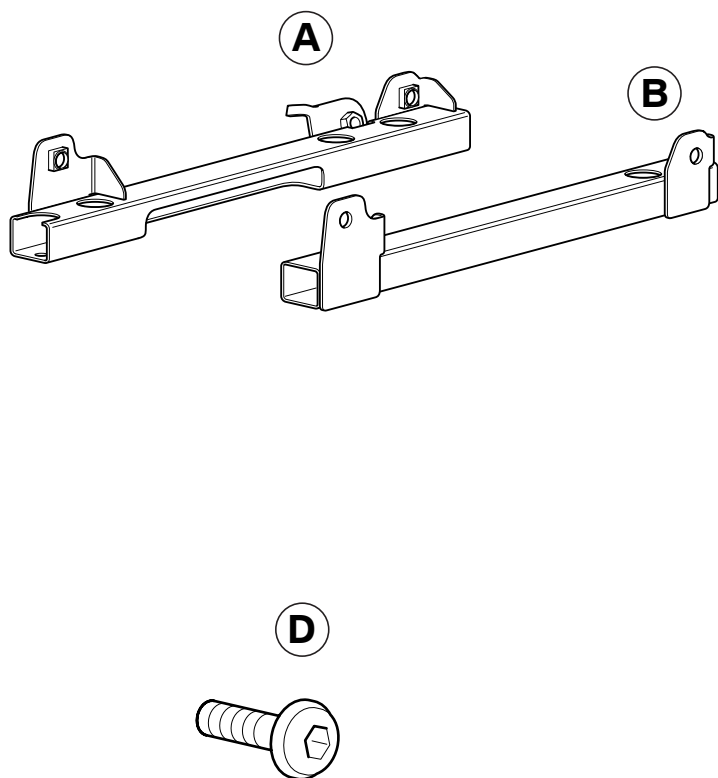

056 0015 M

Legend

- A Inner adapter
- B Outer adapter
- C John Cooper Works Sport seat
- D Hexagon socket head screw M8 x 16 mm (8x)

2. Preparatory work

	TIS No.
Perform quick test	—
Disconnect negative terminal of battery	12 00 ...
The following components must be removed beforehand:	
Remove driver's seat or passenger's seat	52 13 000
Remove seat runner	52 13 010
Remove seat belt tensioner	72 11 041

3. Installing John Cooper Works Sport Seat

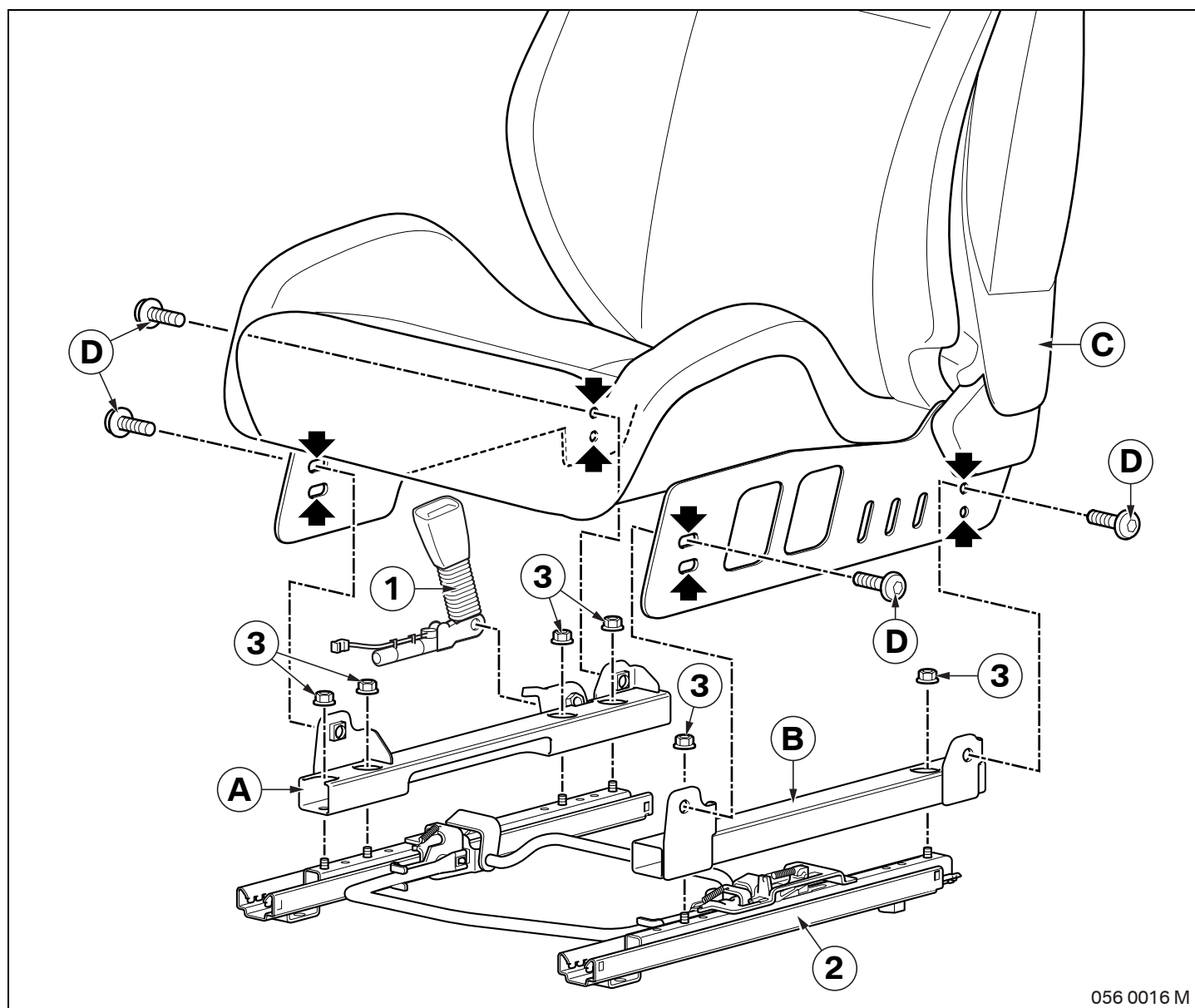

Fit seat belt tensioner (1) on adapter **A**, see TIS No. 72 11 041.

Secure adapters **A** and **B** on seat runner (2) with the existing hexagon nuts (3).

 The tightening torque is 30 – 40 Nm. ◀

 The socket head cap screws **D** are micro-encapsulated. They are used only once. ◀

 The height and angle of the John Cooper Works Sport seat **C** can be individually adjusted by means of the holes (arrows) corresponding to customer requirements. Consult the customer before installing. ◀

Secure seat runner (2) to John Cooper Works Sport seat **C** with socket head cap screws **D**.

 The tightening torque is 24 ± 2 Nm. ◀

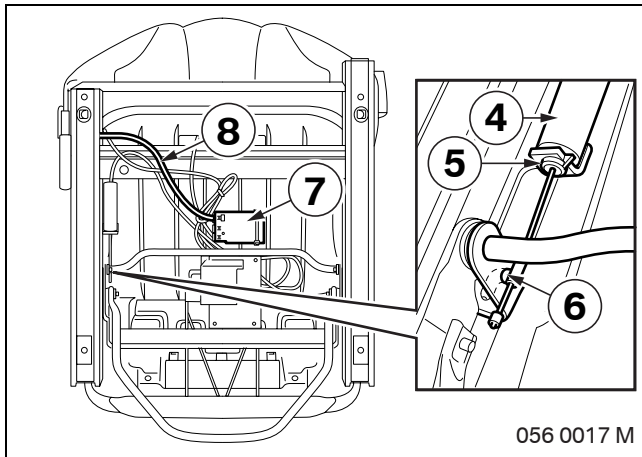

Pass easy/entry cable (4) through bracket (5) and fit hook through hole (6) in bar for seat forward/backward adjustment.

Plug connector of cable (8) for seat belt tensioner into central socket (7).

4. Concluding work and coding

	TIS No.
Reinstall driver's seat or passenger's seat	52 13 000
Reconnect negative terminal of battery	12 00 ...

The retrofit system requires encoding.

- Encode/program retrofit with software service station (SSS) with the path - **Retrofit**.
- Uncode seat occupancy detector for front passenger's seat.
- Perform quick test
- Perform function test
- Reassemble vehicle in reverse order of removal.

5. Customer information

 This customer information is to be kept in the vehicle. ◀

 The vehicle's operating permit is not invalidated by retrofitting the John Cooper Works Sport seat. The John Cooper Works Sport seat is a constituent part of the European operating permit of the MINI R56. Acceptance of the retrofit by a technical inspection organisation as well as corresponding entry in the vehicle papers is not necessary. ◀

Note

 Retrofitting the John Cooper Works Sport seat will deactivate the seat belt reminder for the front passenger seat. The driver is advised to remind the front passenger to fasten his/her seat belt. Deactivation of the seat belt reminder has no influence on operation of the front passenger airbag.

The purchaser must be informed accordingly when selling the vehicle. ◀

 The seat occupancy detector for the front passenger seat must be encoded after reinstalling the original seats. Please consult your MINI dealer. ◀

Seat position

The John Cooper Works Sport seat can be installed in 4 positions for individual height and inclination settings.

 Recommended position: Install the John Cooper Works Sport seat with a backward incline for the driver and front passenger taller than approx. 1.70 m.

 The John Cooper Works Sport seat is a safety component in the vehicle and must be secured with the bolts tightened to a specified torque.

Have changes to the seat height and inclination performed by your MINI dealer. ◀