

Original MINI Zubehör. (from MotoringFile.com)



Park Distance Control (PDC) retrofit kit, front MINI ONE and COOPER (R50) MINI Convertible (R52) MINI COOPER S (R53)

Retrofit kit No. 66 21 0 303 095 Park Distance Control (PDC) front retrofit kit

Installation time

The installation time is 1.5 – 2.0 hours, but this may vary depending on the condition of the car and the equipment in it.

Important information

These installation instructions are primarily designed for use within the MINI dealership organisation and by authorised MINI service companies.

In any event the target group for these installation instructions is specialist personnel trained on MINI cars with the appropriate specialist knowledge.

All work must be completed using the latest MINI repair manuals, circuit diagrams, servicing manuals and work instructions in a rational order using the prescribed tools (special tools) and observing current health and safety regulations.

To avoid unnecessary extra work and/or costs, if any installation or function problems occur, after a brief troubleshooting session (approx. 0.5 hours), contact the following:

- 1. Either your national subsidiary or your regional office**
- 2. The Support team via the Aftersales Assistance Portal (ASAP) using the optional technical parts support application.**

Specify the chassis number and the part number of the installed retrofit kit and give a precise description of the problem.

Do not archive the hard copy of these installation instructions since daily updates are made by Aftersales Portal.

See ASAP for details of the pictograms.

Pictograms



Denotes instructions that draw your attention to dangers.



Denotes instructions that draw your attention to special features.

◀ denotes the end of the instruction or other text.

Subject to technical modifications.

Print out section 10 of these installation instructions and give it to the customer.

Installation information

Ensure that the cables/lines are not kinked or damaged as you install them in the car. The costs incurred as a result of this will not be reimbursed by BMW AG.

Additional cables/lines that you install must be secured with cable ties.

If the specified PIN chambers are occupied, bridges, double crimps or twin-lead terminals must be used.

All the figures show LHD cars, proceed in exactly the same way on RHD cars.

Ordering instructions

The registration plate holder **H** is not included in the retrofit kit and must be ordered separately (see EPC for part number and further details).

Special tools required

None

Contents

Section	Page
1. Parts list.....	4
2. Preparations.....	5
3. Connection diagram.....	6
4. Wiring harness installation and cabling diagram.....	7
5. To install the sensors and registration plate holder.....	8
6. To install the signal sensor and button.....	10
7. To install and connect the wiring harness.....	11
8. Concluding work and coding.....	13
9. Circuit diagram.....	14
10. Customer information for using the front Park Distance Control (PDC).....	16

1. Parts list

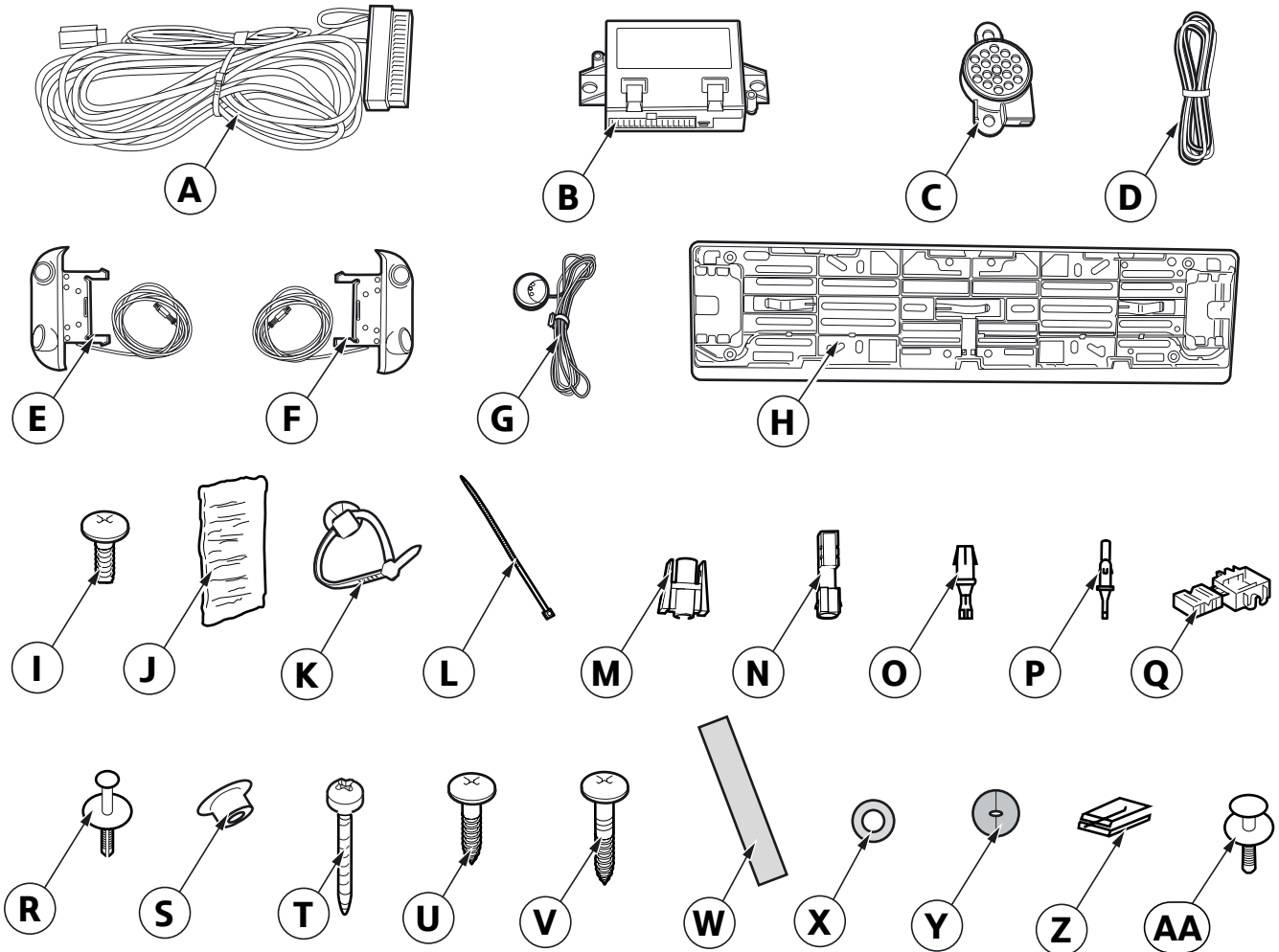

R50 1225 Z

Legend

A	Wiring harness	O	Socket contact
B	Control module	P	Plug contact
C	Signal generator	Q	Miniature connector (4x)
D	Signal generator cable	R	Expanding rivet, 6 mm (4x)
E	Sensor right (marked A)	S	Spacer bush (4x)
F	Sensor left (marked B)	T	Philips screw ST4.2 x 38 mm (4x)
G	Button	U	Philips screw 4,8 x 15 mm (4x)
H	Registration plate holder (not supplied with the retrofit kit)	V	Philips screw 4.8 x 20 mm (8x, not required)
I	Philips screw TS 5 x 8 mm (4x, not required)	W	Sealing strip (2x, not required)
J	Protective strip	X	Rubber grommet (not required)
K	Cable tie holder	Y	2-piece rubber grommet (not required)
L	Cable tie 200 x 3.6 mm (20x)	Z	Velcro strip (not required)
M	Socket casing	AA	Expanding rivet 8 mm (2x, not required)
N	Plug casing		

2. Preparations

	TIS No.
Conduct a brief test	---
Disconnect the negative pole of the battery	12 00 ...
The following components must be removed first of all	
Front bumper trim	51 11 156
Registration plate holder (if supplied, part not required)	---
Oddments box (on the driver's side)	51 16 392
Inside door sill strip, front left	51 47 000
Release the fuse holder	---
Bottom steering column trim	---

3. Connection diagram

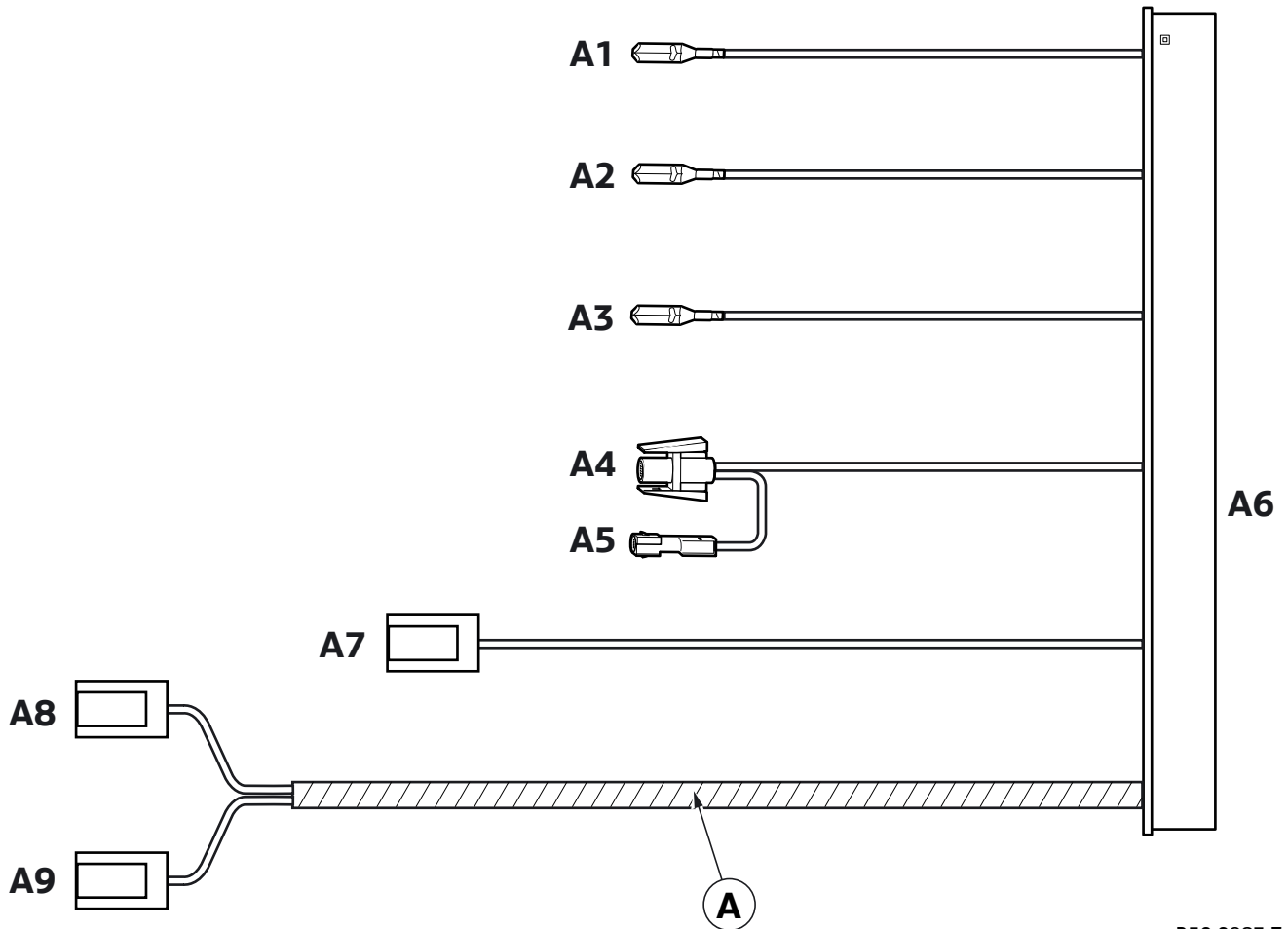

R50 0983 Z

Branch/Item	Description	Signal	Cable colour / Cross-section	Connection location in the car	Abbreviation / Slot
A	Wiring harness	---	---	---	---
A1	Joint connector contact	Terminal 31	BR 0.75 mm ²	To joint connector, left door sill strip	X1108
A2	Joint connector contact	Terminal TAA	WS/SW 0.50 mm ²	To joint connector, left door sill strip	X1108
A3	Joint connector contact	Terminal RS	GE/BL 0.50 mm ²	To joint connector, left door sill strip	X1169
A4	1-pin socket casing, SW	Terminal 15	GN/WS 0.75 mm ²	To fuse holder A47 , with plug casing to GN/GE cable from fusible link F35	X10204 PIN 10
A5	SW 1-pin plug casing	Terminal 15	GN/WS 0.75 mm ²	To fuse holder A47 , with socket casing to GN/GE cable from fusible link F35	X10204 PIN 10
A6	WS 24-pin socket casing	---	---	To control module B	---
A7	SW 2-pin plug casing	---	---	To connection cable for button G	---
A8	4-pin socket casing, SW (marked A)	---	---	To sensor cable on the right sensor E (marked A)	---
A9	4-pin socket casing, SW (marked B)	---	---	To sensor cable on the left sensor F (marked B)	---

4. Wiring harness installation and cabling diagram

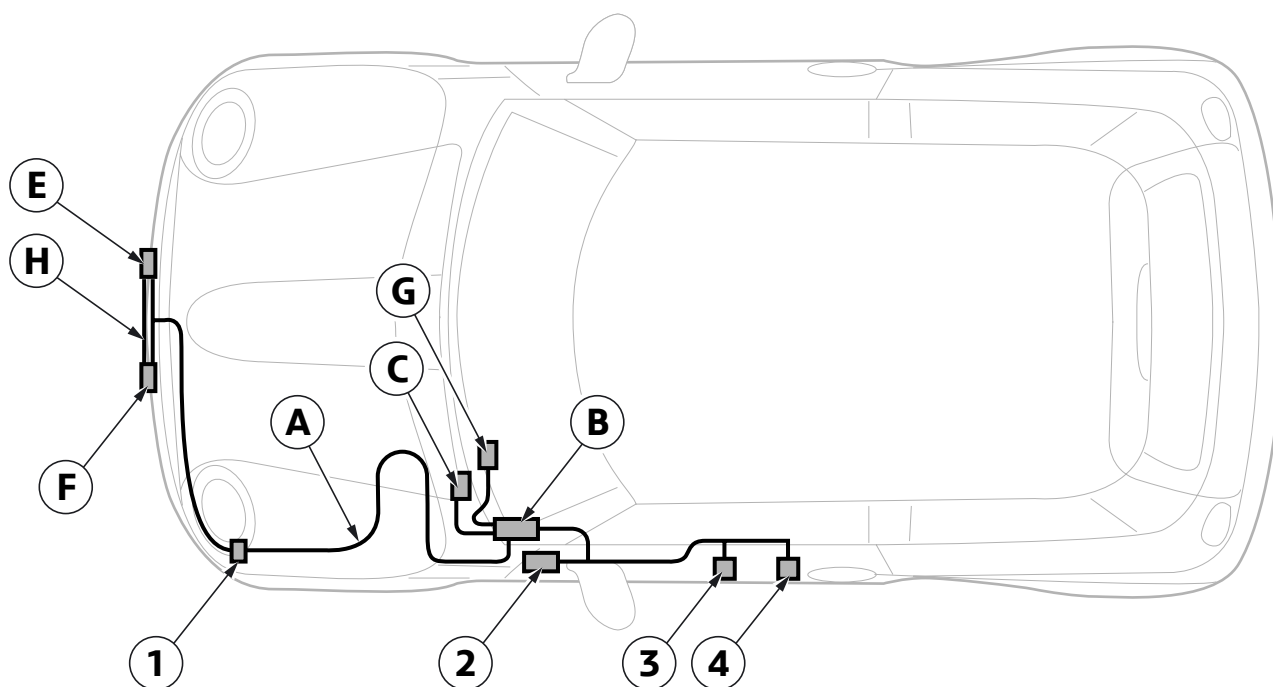

R50 0982 Z

Legend

- A Wiring harness
 - B Control module
 - C Signal generator
 - E Sensor right
 - F Sensor left
 - G Button
 - H Registration plate holder
-
- 1 Plug connector
 - 2 Terminal 15 tap up on fuse holder, plug **X10204**
 - 3 Terminal 31 tap on joint connector **X1108**
 - 4 Terminal RS tap on joint connector **X1169**

5. To install the sensors and registration plate holder

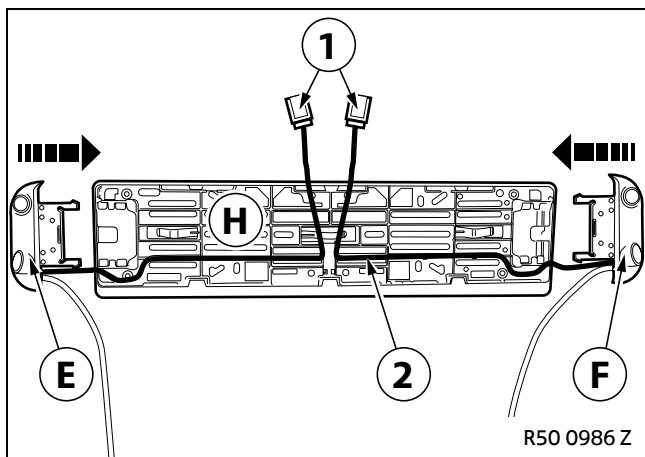

Plug right sensor **E** and left sensor **F** into the registration plate holder **H**.

Place the sensor cable (1) in groove (2).

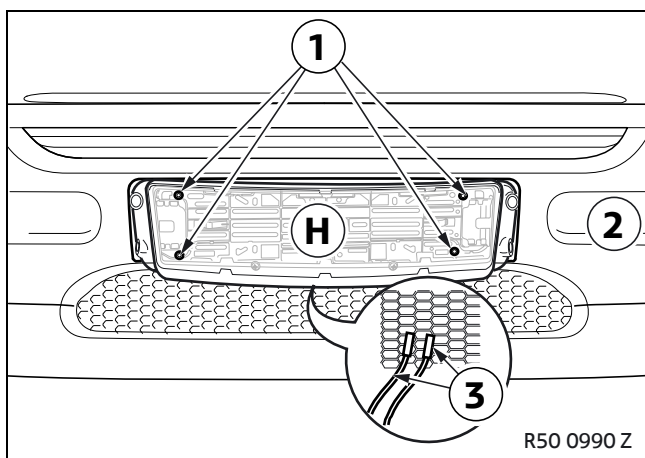

Cars with countersunk registration plate only

Place registration plate holder **H** on the bumper trim (2) and mark the positions for the holes (1).

Drill through the bumper trim (2) using a 3.0 mm twist drill bit.

Route the sensor cable (3) through the grille.

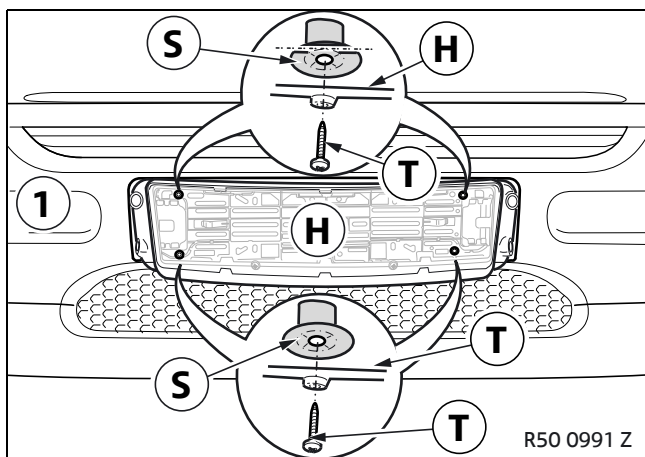

 Cut off the discs from upper spacer bushes **S** so they do not project beyond registration plate holder **H**. ◀

Screw the registration plate holder **H** to the bumper trim (1) with spacer bushes **S** and Philips screws **T** (1).

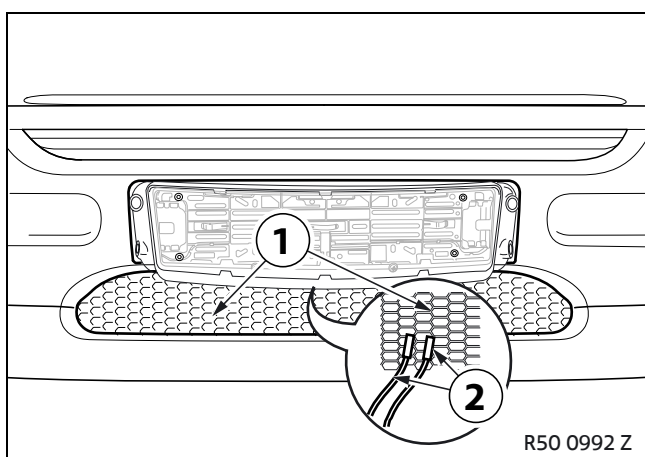

Route the sensor cable (2) through the grille (1).

5. To install the sensors and registration plate holder

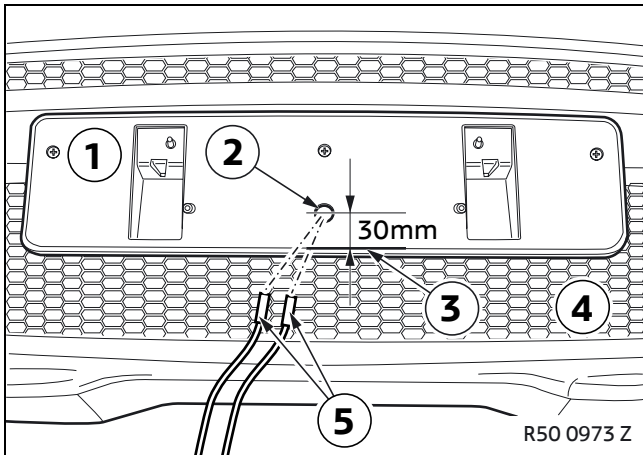

Cars with mounted registration plate only

Mark the position of the hole (2) on the support (1) as follows:

- Centre
- Approx. 30 mm from the edge (3)

Drill through the support (1) at the position of the hole (2) using a 14 mm step drill bit.

Route the sensor cable (5) through the hole (2) and the grille (4).

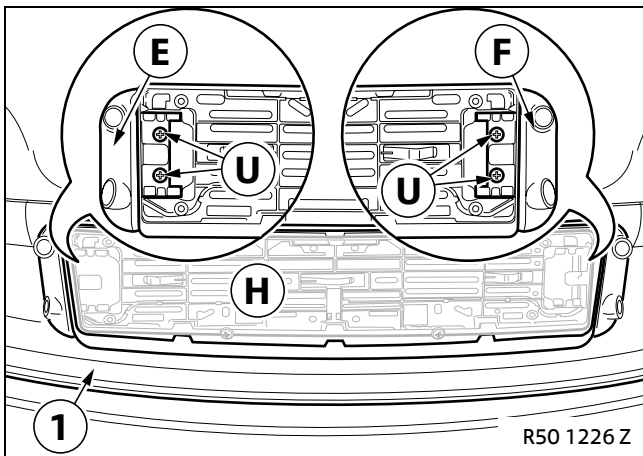

Install the registration plate holder **H** on the bumper trim (1) as follows:

- Secure the registration plate holder **H** using the registration plate screws
- Secure the right sensor **E** and left sensor **F** using Philips screws **U**

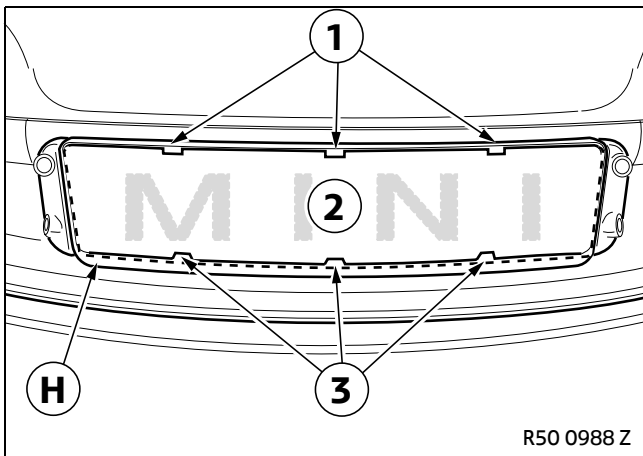

All cars

Insert the registration plate (2) into registration plate holder **H** as follows:

- Insert the registration plate (2) behind the bottom lugs (3)
- Lock the registration plate (2) behind the top lugs (1)

6. To install the signal sensor and button

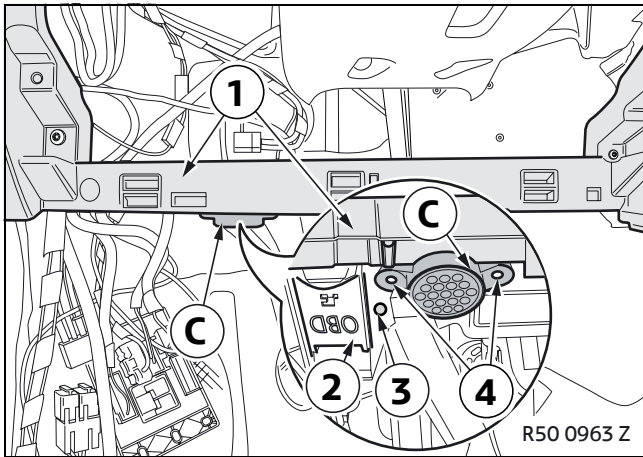

Place the signal generator **C** on to the instrument holder (1) next to the OBD socket (2) as shown.

 Do not damage the cable. ◀

Mark the holes (4) and use a 6 mm twist drill bit to drill through the instrument holder (1).

Use an 8 mm twist drill bit to drill a cable passage (3) at a suitable point.

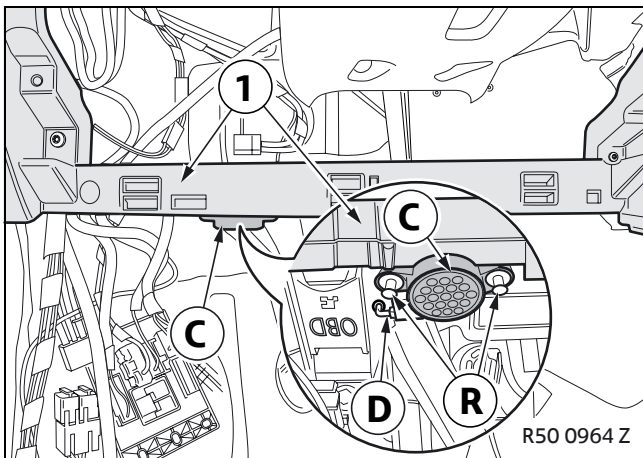

Use expanding rivets **R** to secure the signal generator **C** to the instrument holder (1).

Route the signal generator cable **D** through the cable passage and connect it to signal generator **C**.

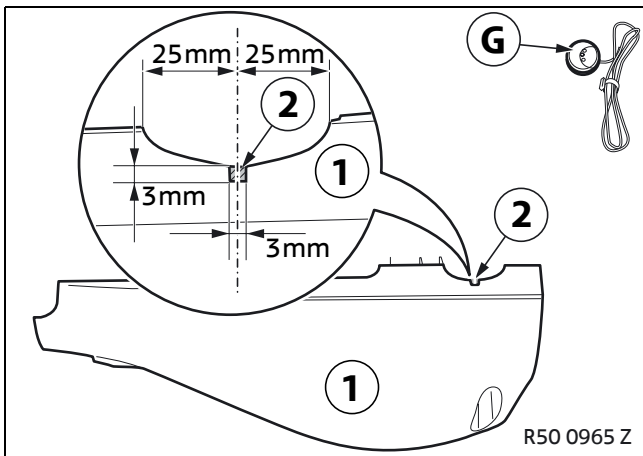

Mark the specified dimensions on the lower steering column trim (1).

File a notch in the marked area (2) for the connection cable of button **G**.

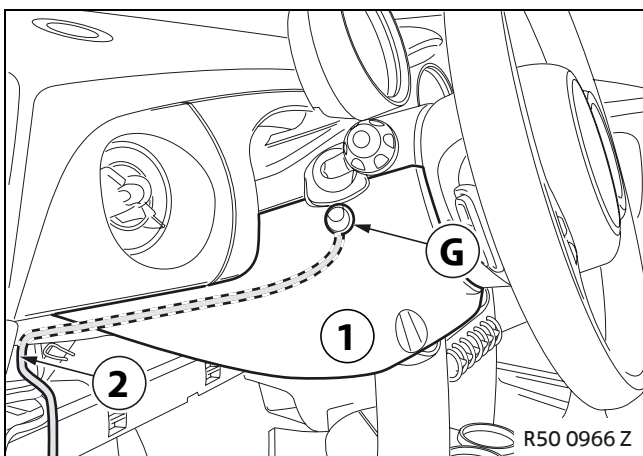

Clean the bottom steering column casing (1) and affix the button **G**.

Install the lower steering column trim (1).

Route the connection cable (2) for the button **G** into the footwell.

7. To install and connect the wiring harness

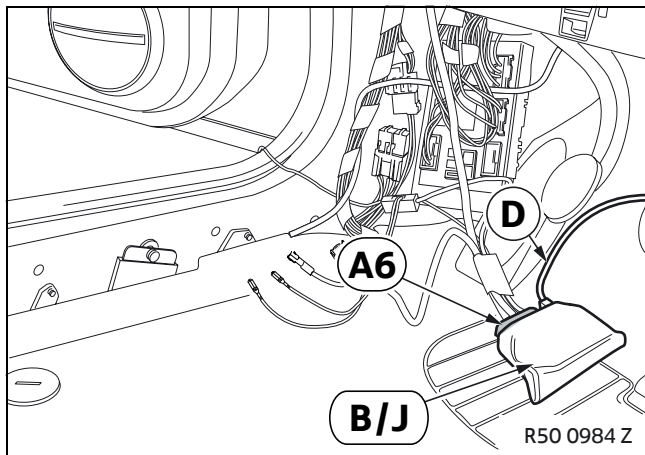

Connect branch **A6** and the signal sensor cable **D** to the control module **B**.

Wrap the control module **B** in protective strips **J**.

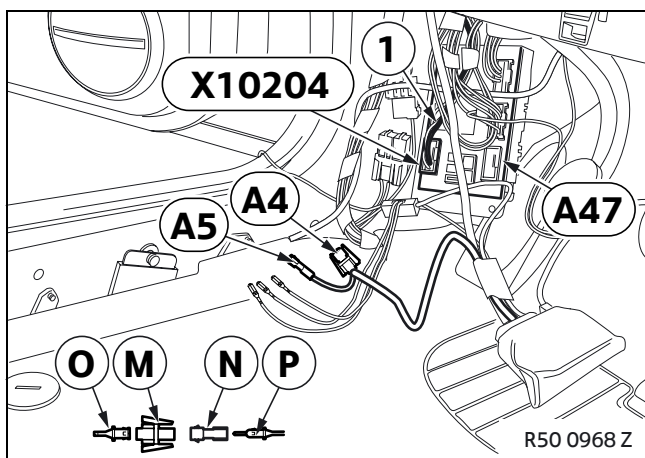

Connect branches **A4** and **A5** to plug **X10204** (natural-coloured 12-pin) on fuse holder **A47**:

- Cut through the outgoing GN/GE cable (PIN 10) at a suitable point
- Crimp socket and plug contacts **O** and **P** to the cut cables (1).
- Connect socket / plug casings **M** and **N**.
- Connect branches **A4** and **A5**.

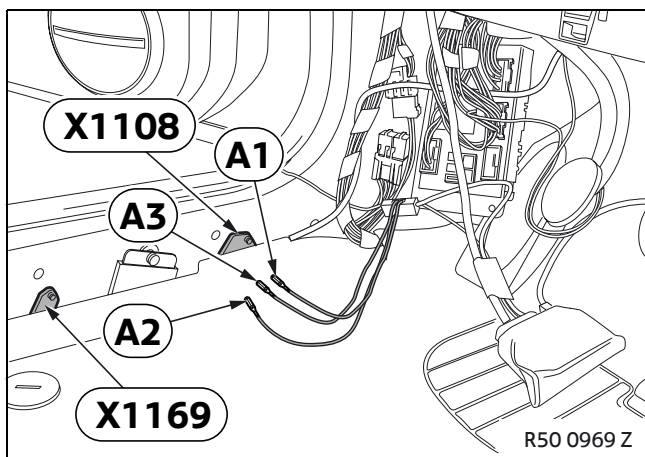

Connect branch **A1**, BR cable, and branch **A2**, WS/SW cable, to the joint connector **X1108**, BR cable.

Connect branch **A3**, GE/BL cable, to joint connector **X1169**, BL/GE cable.

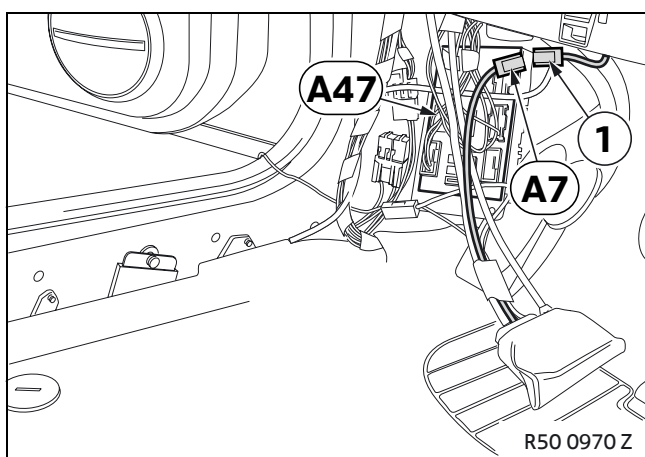

Connect branch **A7** to the connection cable (1) for button **G**.

Install the fuse holder **A47**.

7. To install and connect the wiring harness

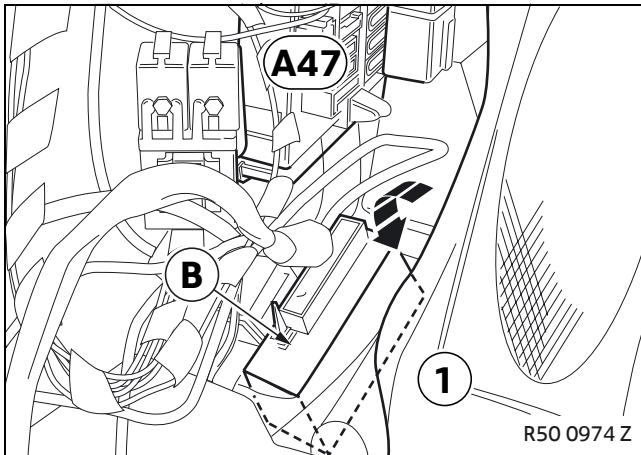

Place the control module **B** between the fuse holder **A47** and the carpet (1).

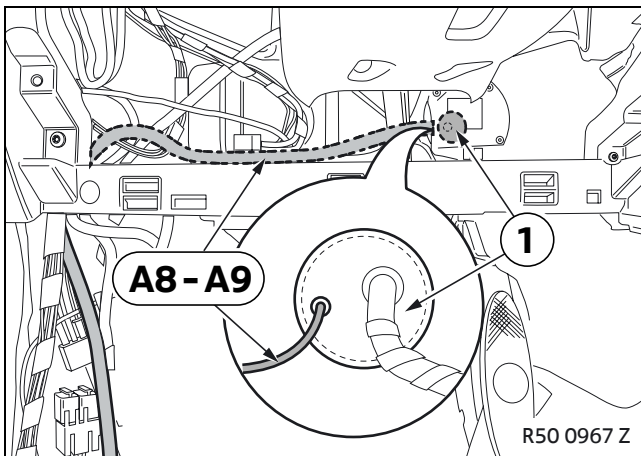

Thread branches **A8** and **A9** through the grommet (1) into the engine compartment.

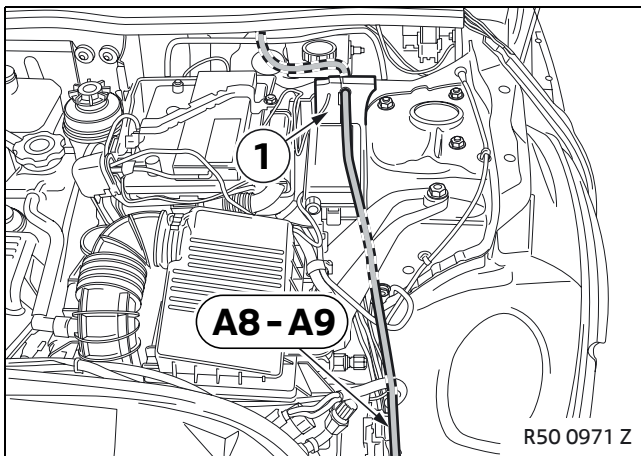

Cut into the cover (1) and make a hole for the cable passage.

Thread branches **A8** and **A9** through the cover (1) towards the front.

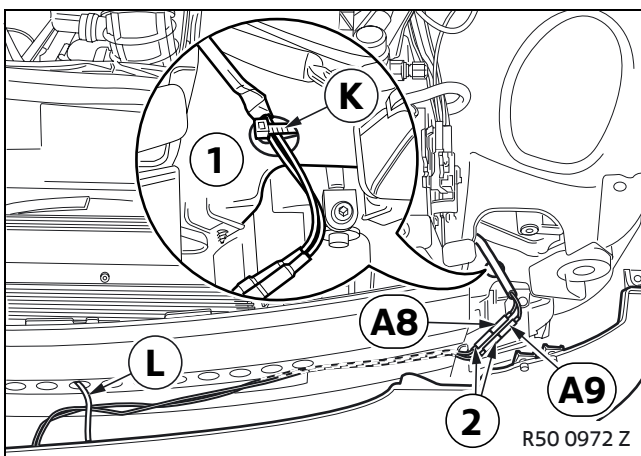

Use a 6 mm twist drill bit to drill through the inner wing (1) at a suitable point and push in cable tie holder **K**.

 To prevent malfunctions by the PDC, observe the marks (A and B). ◀

Connect branch **A8** and branch **A9** to the sensor cables (2) with the matching identification.

Secure the sensor cable (2) with cable tie holder **K** and cable tie **L**.

Install the bumper trim.

8. Concluding work and coding

This retrofit system does not require coding.

- Connect the battery
- Conduct a brief test
- Conduct a function test on the PDC (see section 10)
- Re-assemble the car

9. Circuit diagram

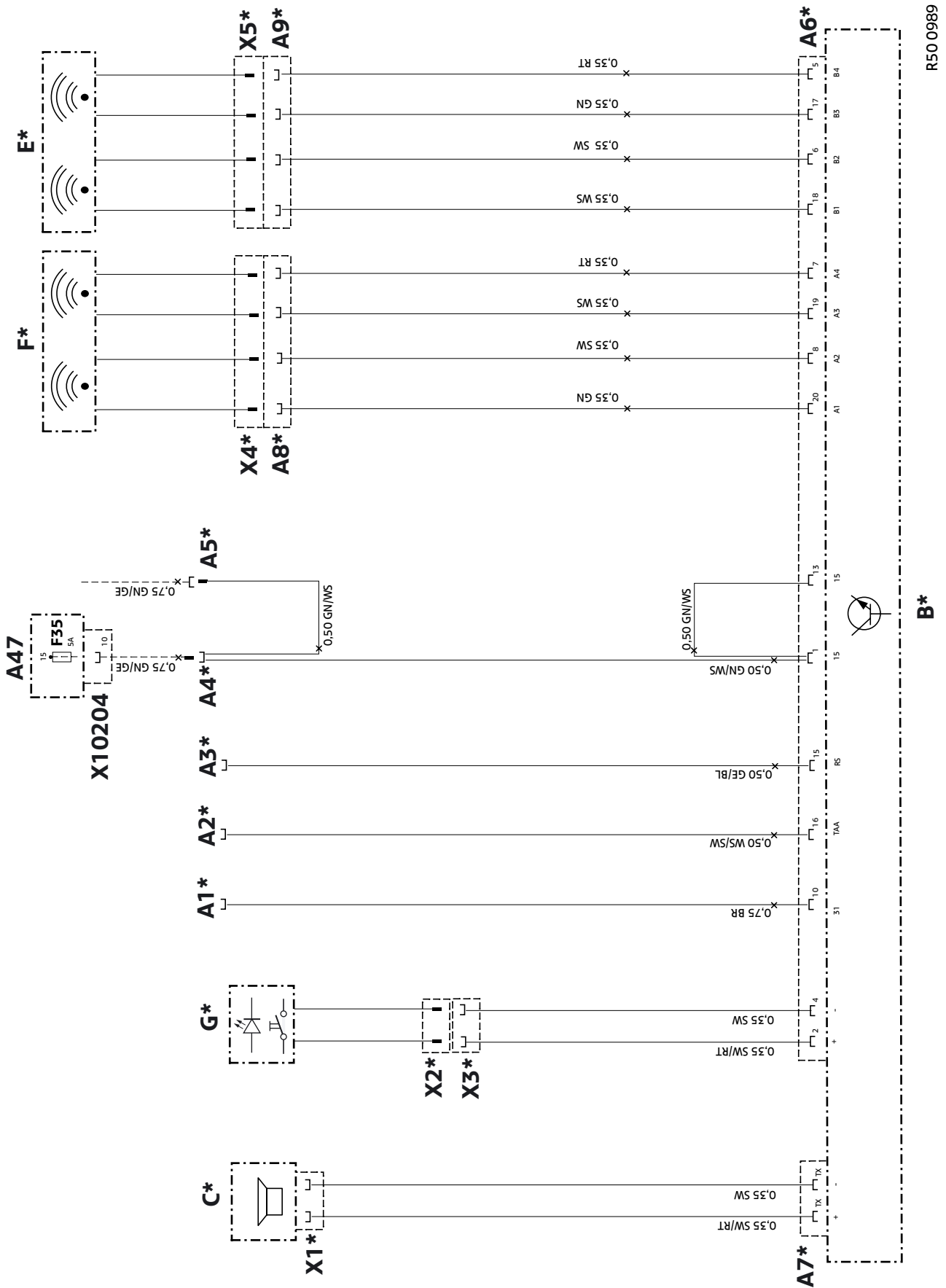

R50 0989 Z

9. Circuit diagram

Legend

A47	Fuse holder
F35	Fusible link 5 A
X10204	12-pin natural socket casing
B*	Control module
C*	Signal generator
E*	Sensor right
F*	Sensor left
G*	Button
A1*	Joint connector contact, terminal 31 tap on joint connector X1108
A2*	Joint connector contact, terminal 31 tap on joint connector X1108
A3*	Joint connector contact, terminal RS tap on joint connector X1169
A4*	Socket contact
A5*	Plug contact
A6*	WS 24-pin socket casing
A7*	2-pin socket casing, SW
A8*	4-pin socket casing, SW
A9*	4-pin socket casing, SW
X1*	2-pin socket casing, SW
X2*	SW 2-pin plug casing
X3*	2-pin socket casing, SW
X4*	SW 4-pin plug casing
X5*	SW 4-pin plug casing

All the designations marked with an asterisk (*) apply only to these installation instructions or this circuit diagram.

Cable colours

BL	Blue
BR	Brown
GE	Yellow
GN	Green
RT	Red
SW	Black
WS	White

10. Customer information for using the front Park Distance Control (PDC)

Print out this customer information and give it to the customer.

Pictograms



Denotes instructions that draw your attention to dangers.



Denotes instructions that draw your attention to special features.

◀ Denotes the end of the instruction or other text.

How it works

The PDC is a system which assists you when parking and manoeuvring.

Using ultrasonic sensors the PDC identifies obstacles in front of your car and notifies you by acoustic signals.

If the PDC identifies an obstacle, you will hear acoustic signals.

The closer the car gets to the obstacle, the faster the acoustic signals become.

A permanent signal sounds when the distance to the obstacle reaches 30 cm.

Operation

As soon as you switch on the ignition the PDC will be activated automatically.

A control lamp (1) on the button (2) indicates when the PDC is ready to operate.

The PDC is switched on when the control lamp (1) is lit.

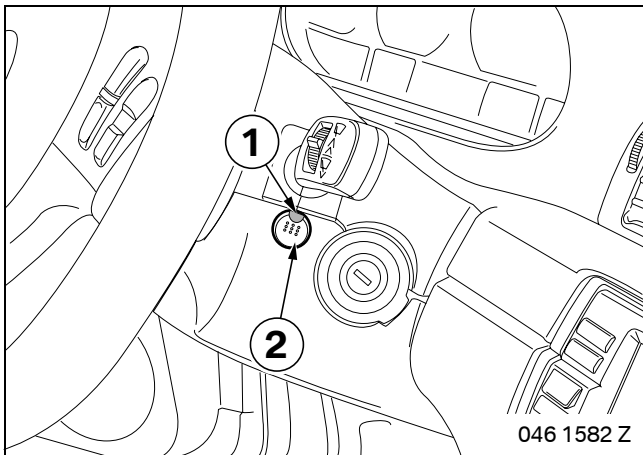

To switch off PDC

- Press the button (2)

The control light (1) will go out.

The PDC is switched off.



As soon as you engage reverse gear, the PDC will again be switched on automatically. ▶

To switch on the PDC manually



As soon as you engage reverse gear, the PDC will again be switched on automatically. ▶

- Press the button (2)

The control light (1) will be lit

The PDC is switched on.



The driver is exclusively responsible for judging obstacles and must therefore maintain a careful and attentive driving style so that he does not cause and damage or injuries. ▶



As with all ultrasonic distance measurement systems, incorrect signals may occur or some obstacles may not register properly.

Depending on the specific car, blind spots may be created in front of the bumper and at its side ends in which obstacles cannot register correctly or complete.

The limit of what can physically be measured may be reached with some very low (lower than 10 cm), narrow (narrower than 6 cm) or pointed obstacles. In certain circumstances the system may not register such obstacles.

To ensure that the PDC functions correctly, you should drive slowly when parking and manoeuvring and clean any snow, ice or dirt off the ultrasonic sensors.

Strong wind, snowfall or rain may cause the system to send incorrect signals. ▶