



# Installation Instructions

Page 1 of 2

September 2005

Body Equipment, Grille Badge Mounting

Ver 1.0

Accessory  
Development

## SUBJECT

**GRILLE BADGE MOUNTING KIT – P/N 51 13 0 406 752**

## MODEL

<b>MINI Cooper (R50):</b>	<b>All Vehicle Production</b>
<b>MINI Cooper S (R53):</b>	<b>All Vehicle Production</b>
<b>MINI Convertible (R52):</b>	<b>All Vehicle Production</b>

**SUGGESTED INSTALLATION TIME:      0.25 HOUR**

The instructions below are developed for MINI vehicles and are not to be compared to any other existing instructions for vehicles other than MINI. No methods other than those specified in this document are to be used for installation in MINI vehicles. Left and right are determined from the driver's seat.

Carefully read all instructions and supplements before proceeding with the installation. Reference should be made to TIS for instructions dealing with a stock part of the vehicle but not stated in detail in these instructions.

The instructions were complete and up to date at time of publication; however, changes to the vehicle or installation may have occurred. Please report any problems or changes noted with the installation to BMW Technical Hotline, along with VIN, date of manufacture and as much detail as possible.

**Warning: No more than two grille badges should be mounted on the grille to ensure sufficient airflow to engine.**

## PARTS INFORMATION

**Contents of Kit - P/N 51 13 0 406 752**

<b>Description</b>	<b>Qty</b>	<b>MINI Part Number</b>
Grille badge base plate	1	N/A
Bent tabs mounting bracket	1	N/A
35mm x 50mm flat mounting bracket	1	N/A
M4 flat washer	2	N/A
M4 lock nut	2	N/A
Installation instructions	1	01 29 0 409 392

**★ ★ DO IT RIGHT THE FIRST TIME, ON TIME, EVERY TIME ★ ★**

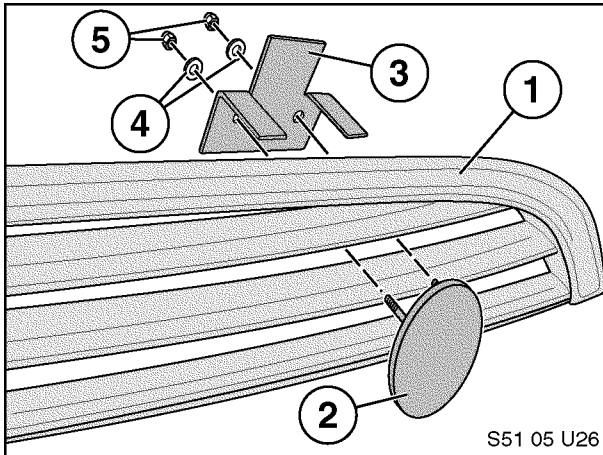
**PROCEDURE:**

S51 05 U26

**Three Fin Grille Badge Base/Bracket Mounting**

1. Place badge base plate (2) so the pair of threaded studs protrude horizontally through lower top fin opening of grille (1) as shown
2. Place 90° bent tabs mounting bracket (3) behind grille with tabs facing forward as shown.
3. Align bracket (3) so that threaded studs of badge base plate (2) pass through openings of mounting bracket (3).
4. Secure badge base plate (2) and mounting bracket (3) securely in place with flat washers (4) and lock nuts (5) as shown.

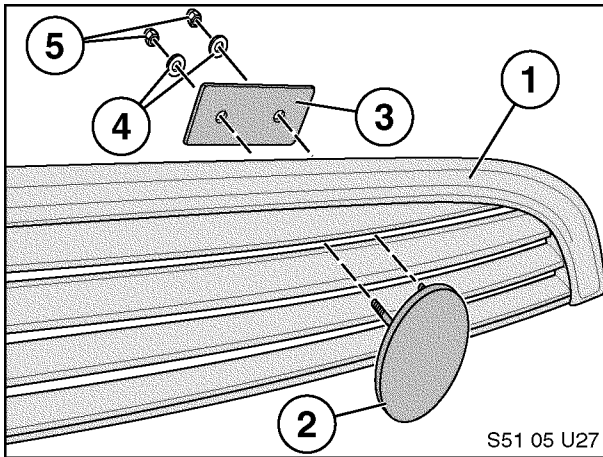

S51 05 U27

**Four Fin Grille Badge Base/Bracket Mounting**

1. Position badge base plate (2) so the pair of threaded studs protrude horizontally through lower top fin opening of grille (1) as shown.
2. Place 35mm x 50mm flat mounting bracket (3) behind grille (1) so that threaded studs of badge base plate (2) protrude through holes in bracket (3).
3. Secure badge base plate (2) and mounting bracket (3) securely in place with flat washers (4) and lock nuts (5) as shown.

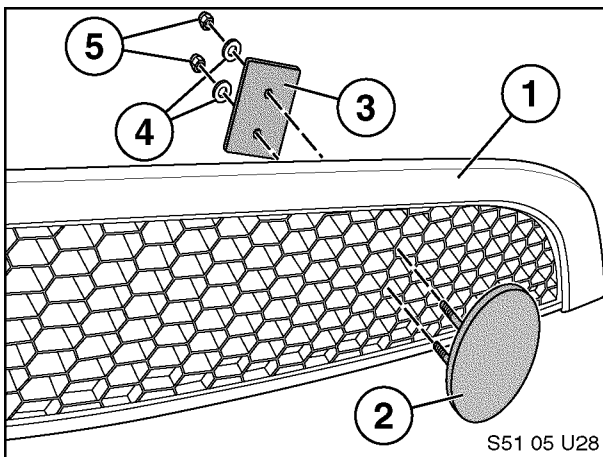

S51 05 U28

**Honeycomb Grille Badge Base/Bracket Mounting**

1. Position badge base plate (2) so the pair of threaded studs protrude vertically through honeycomb openings of grille (1) as shown.
2. Place 35mm x 50mm flat mounting bracket (3) behind grille (1) so that threaded studs of badge base plate (2) protrude through holes in bracket (3).
3. Secure badge base plate (2) and mounting bracket (3) securely in place with flat washers (4) and lock nuts (5) as shown.

**Warning: No more than two grille badges should be mounted on the grille to ensure sufficient airflow to engine.**